



UNIVERSITY OF CALICUT

Abstract

General and Academic - Faculty of Science - Modified Syllabus of BSc Physics Programme under CBCSS UG Regulations 2019 with effect from 2020 Admission onwards - Implemented- Orders Issued.

G & A - IV - J

U.O.No. 6321/2020/Admn

Dated, Calicut University.P.O, 07.07.2020

- Read:-**
1. U.O.No. 4368/2019/Admn dated 23.03.2019
 2. U.O.No. 18084/2019/Admn Dated 28.12.2019
 3. The item No.5 in the minutes of the meeting of the Board of Studies in Physics UG held on 05.03.2020
 4. Remarks of the Dean, Faculty of Science dtd 08.06.2020
 5. Order of the Vice Chancellor in the file even no. dtd 11.06.2020

ORDER

1. The Regulations for Choice Based Credit and Semester System for Under Graduate (UG) Curriculum-2019 (CBCSS UG Regulations 2019) for all UG Programmes under CBCSS-Regular and SDE/PrivateRegistration w.e.f. 2019 admission, has been implemented vide paper read first above and the same has been modified vide paper read second above.
2. The meeting of the Board of Studies in Physics (UG) held on 05/06/2020 has recommended the following modifications in the I and II semester of the Syllabus of B.Sc Physics Programme in tune with the new CBCSS UG - 2019 Regulations with effect from 2020 Admission, vide paper read third above.
 - Two units in semester I should be removed. The title of the course changed to Mechanics-I.
 - The syllabus of the unit, "Waves" in the syllabus of semester II is modified with another standard text book as book of study. The title of the course changed to Mechanics-II.
3. The Dean, Faculty of Science has approved the modified syllabus of BSc Physics programme in tune with the new CBCSS UG-2019 Regulations with effect from 2020 Admission onwards, vide paper read fourth above.
4. Considering the urgency of the matter, the Vice Chancellor has accorded sanction to implement the Scheme and Syllabus of B Sc Physics Programme in accordance with the new CBCSS UG Regulations 2019, in the University with effect from 2020 Admission onwards, subject to ratification by the Academic Council.
5. The Modified Scheme and Syllabus of B Sc Physics Programme in accordance with CBCSS UG Regulations 2019, is therefore implemented in the University with effect from 2020 Admission onwards.
6. Orders are issued accordingly. (Syllabus appended).

Arsad M

Assistant Registrar

To

The Principals of all Affiliated Colleges
Copy to: PS to VC/PA to PVC/ PA to Registrar/PA to CE/JCE I/JCE IV/DoA/EX and EG
Sections/GA I F/CHMK Library/Information Centres/SF/DF/FC

Forwarded / By Order

Section Officer

+

UNIVERSITY OF CALICUT

B.Sc. PHYSICS

(CORE AND COMPLEMENTARY PROGRAMMES)

SYLLABUS & MODEL QUESTION PAPERS

w.e.f 2020 admission onwards

CBCSSUG Regulations 2020

B.Sc. PHYSICS
CORE & COMPLEMENTARY PROGRAMMES
SYLLABUS

PROGRAMME: B.Sc. PHYSICS

Programme Specific Outcomes

PSO1: Understand the basic concepts of fundamentals of mechanics, properties of matter and electrodynamics

PSO2: Understand the theoretical basis of quantum mechanics, relativistic physics, nuclear physics, optics, spectroscopy, solid state physics, astrophysics, statistical physics, photonics and thermodynamics

PSO3: Understand and apply the concepts of electronics in the designing of different analog and digital circuits

PSO4: Understand the basics of computer programming and numerical analysis

PSO5: Apply and verify theoretical concepts through laboratory experiments

Abbreviations used:

CL – Cognitive level; **U** – understand; **Ap** – apply; **An** – analyze; **C** - create

KC – Knowledge category; **C** – conceptual; **F** – factual; **P** - procedural

B.Sc. DEGREE PROGRAMME (PHYSICS CORE)

COURSE STRUCTURE

Semester	Course Code	Course Title	Total hours	Hours/Week	Credits
1	A 01	Common Course I – English	72	4	4
	A 02	Common Course II – English	90	5	3
	A 07	Common Course III – Language other than English	72	4	4
	PHY1 B01	Core course I - Mechanics I	36	2	2
		Core Course V - Practical I	36	2	*
		1 st Complementary Course I - Mathematics	72	4	3
		2 nd Complementary Course I	36	2	2
		2 nd Complementary Course Practical I	36	2	*
	EO1	Environment Studies	-	-	4**
	Total	450	25	18	
2	A 03	Common Course IV – English	72	4	4
	A 04	Common Course V – English	90	5	3
	A 08	Common Course VI – Language other than English	72	4	4
	PHY2 B02	Core Course II - Mechanics II	36	2	2
		Core Course V - Practical I	36	2	*
		1 st Complementary Course II - Mathematics	72	4	3
		2 nd Complementary Course II	36	2	2
		2 nd Complementary Course Practical II	36	2	*
	E02	Disaster Management			4**
	Total	450	25	18	
3	A 05	Common Course VI – English	90	5	4
	A 09	Common Course VIII - Language other than English	90	5	4
	PHY3 B03	Core Course III – Electrodynamics-I	54	3	3

		Core Course VI- Practical I	36	2	*
		1 st Complementary Course III – Mathematics	90	5	3
		2 nd Complementary Course III	54	3	2
		2 nd Complementary Course Practical III	36	2	*
E03		Human Rights or Intellectual Property Rights or Consumer protection			4**
		Total	450	25	16
4	A 06	Common Course IX – English	90	5	4
	A 10	Common Course X - Language other than English	90	5	4
	PHY4 B04	Core Course IV - Electrodynamics II	54	3	3
	PHY4 B05	Core Course Practical V – Practical I	36	2	5
		1 st Complementary Course IV– Mathematics	90	5	3
		2 nd Complementary Course IV	54	3	2
		2 nd Complementary Course Practical IV	36	2	4
	E04	Gender studies or Gerontology			4**
	Total	450	25	25	
5	PHY5 B06	Core Course VI - Computational Physics	54	3	3
	PHY5 B07	Core Course VII - Quantum Mechanics	54	3	3
	PHY5 B08	Core Course VIII - Optics	54	3	3
	PHY5 B09	Core Course IX- Electronics (Analog and Digital)	54	3	3
		Open Course – (<i>course from other streams</i>)	54	3	3
		Core Course Practical XIV - Practical II	72	4	*
		Core Course Practical XV- Practical III	72	4	*
		Core Course XVII Project/Research methodology	36	2	*
	Total	450	25	15	
6	PHY6 B10	Core Course X - Thermodynamics	54	3	3
	PHY6 B11	Core Course XI -Statistical Physics, Solid State Physics, Spectroscopy and Photonics	54	3	3
	PHY6 B12	Core Course XII - Nuclear Physics and Particle Physics	54	3	3

PHY6 B13	Core Course XIII - Relativistic Mechanics and Astrophysics	54	3	3
PHY6 B14	Core Course XIV (Elective:EL1 / EL2 / EL3)	54	3	3
PHY6 B15	Core Course Practical XV – Practical II	72	4	5
PHY6 B16	Core Course Practical XVI – Practical III	72	4	5
PHY6 B17 (P/R)	Core Course XVII Project/Research methodology Tour report	36	2	2 1
	Total	450	25	28
Total Credits				120

Tour report shall be evaluated with Practical III

*Credit for practical / project to be awarded only at the end of Semester 4 and Semester 6.

**Mandatory audit courses for the program, but not counted for the calculation of SGPA or CGPA.

Student can attain only pass (Grade P) for these courses.

CREDIT AND MARK DISTRIBUTION IN EACH SEMESTERS

Total Credits: 120; Total Marks: 3075

<i>Semester</i>	<i>Course</i>	<i>Credit</i>	<i>Marks</i>
1	Common course: English	4	100
	Common course: English	3	75
	Common course: Additional Language	4	100
	Core Course I: Mechanics I	2	75
	Complementary course: Mathematics	3	75
	Complementary course: II	2	75
	Total	18	500
2	Common course: English	4	100
	Common course: English	3	75
	Common course: Additional Language	4	100
	Core Course II: Mechanics II	2	75
	Complementary course: Mathematics	3	75
	Complementary course: II	2	75
	Total	18	500
3	Common course: English	4	100
	Common course: Additional Language	4	100
	Core Course III: Electrodynamics-I	3	75
	Complementary course: Mathematics	3	75
	Complementary course: II	2	75
	Total	16	425
4	Common course: English	4	100
	Common course: Additional Language	4	100
	Core Course IV: Electrodynamics-II	3	75
	Core Course V: Physics Practical I	5	100
	Complementary course: Mathematics	3	75
	Complementary course: II	2	75
	Complementary course: II Practical	4	100
	Total	25	625
5	Core Course VI: Computational Physics	3	75
	Core Course VII :Quantum Mechanics	3	75
	Core Course VIII: Optics	3	75
	Core Course IX: Electronics (Analog and Digital)	3	75
	Open course	3	75
	Total	15	375

6	Core Course X: Thermodynamics	3	75
	Core Course XI: Statistical Physics, Solid State Physics, Spectroscopy and Photonics	3	75
	Core Course XII: Nuclear Physics and Particle Physics	3	75
	Core Course XIII: Relativistic mechanics and Astrophysics	3	75
	Core Course XIV: Elective (EL1 / EL2 / EL3)	3	75
	Core Course XV: Practical II	5	100
	Core Course XVI: Practical III	5	100
	Core Course XVII: Project/Research Methodology	2	60
	Tour report	1	15
	Total	28	650
Grand Total	120	3075	

COURSE STRUCTURE PHYSICS(CORE)

Credit Distribution

Semester	Common course		Core course	Complementary course		Open course	Total
	English	Additional Language		Mathematics	Comple. II		
2	4+3	4	2	3	2	-	18
3	4	4	3	3	2	-	16
4	4	4	3+5*	3	2+4*	-	25
5	-	-	3+3+3+3	-	-	3	15
6	-	-	3+3+3+3+3 +5*+5*+3**	-	-	-	28
Total	22	16	55	12	12	3	120

*Practical **Project

Tour Report to be evaluated with Practical Paper III

Mark Distribution and Indirect Grading System

Indirect grading system is to be followed for examinations of all courses. After external and internal evaluations marks are entered in the answer scripts. All other calculations, including grading, will be done by the university using the software. Indirect Grading System in 8 point scale is followed. Each course is evaluated by assigning marks with a letter grade (O, A+, A, B+, B, C, P or F to that course by the method of indirect grading.

Mark Distribution

Sl. No.	Course	Marks
1	English	550
2	Additional Language	400
3	Core course: Physics	1350
4	Complementary course I: Mathematics	300
5	Complementary course II: Chemistry/...	400
6	Open Course	75
	Total Marks	3075

Eight point Indirect Grading System

% of Marks	Grade	Interpretation	Grade Point Average	Range of Grade points	Class
95 and above	O	Outstanding	10	9.5 - 10	First Class with distinction
85 to below 95	A+	Excellent	9	8.5 - 9.49	
75 to below 85	A	Very good	8	7.5-8.49	
65 to below 75	B+	Good	7	6.5 -7.49	First Class
55 to below 65	B	Satisfactory	6	5.5 - 6.49	

45 to below 55	C	Average	5	4.5 – 5.49	Second Class
35 to below 45	P	Pass	4	3.5 – 4.49	Third class
Below 35	F	Fail	0	0 – 3.49	Fail

Core Course Structure
Total Credits: 56 (Internal: 20%; External: 80%)

<i>Semester</i>	<i>Code No</i>	<i>Course Title</i>	<i>Hours/Week</i>	<i>Total Hours</i>	<i>Credit</i>	<i>Marks</i>
1	PHY1B01	Core Course I: Mechanics I	2	36	2	75
	-	Core Course V : Practical-I	2	36	-*	-
2	PHY2B02	Core Course II: Mechanics II	2	36	2	75
	-	Core Course V : Practical-I	2	36	-*	-
3	PHY3B03	Core Course III: Electrodynamics-I	3	54	3	75
	-	Core Course V : Practical-I	2	36	-*	-
4	PHY4B04	Core Course IV: Electrodynamics-II	3	54	3	75
	PHY4B05	Core Course V : Practical-I	2	36	5	100
5	PHY5B06	Core Course VI: Computational Physics	3	54	3	75
	PHY5B07	Core Course VII: Quantum Mechanics	3	54	3	75
	PHY5B08	Core Course VIII: Optics	3	54	3	75
	PHY5B09	Core Course IX: Electronics (Analog and Digital)	3	54	3	75
		Core Course XIV: Practical II	4	72	-**	-
		Core Course XV: Practical III	4	72	-**	-
		Core Course XVII: Project Work	2	36	-**	-
6	PHY6B10	Core Course X: Thermodynamics	3	54	3	75
	PHY6B11	Core Course XI: Statistical Physics, Solid State Physics, Spectroscopy and Photonics	3	54	3	75
	PHY6B12	Core Course XII: Nuclear Physics and Particle Physics	3	54	3	75
	PHY6B13	Core Course XIII Relativistic mechanics and Astrophysics	3	54	3	75

PHY6B14 (EL1)	Core Course XIV: Elective***	1. Biomedical Physics	3	54	3	75
PHY6B14 (EL2)		2. Nanoscience and Technology				
PHY6B14 (EL3)		3. Materials Science				
PHY6B15	Core Course XV: Practical -II		4	72	5**	100
PHY6B16	Core Course XVI: Practical-III		4	72	5**	100
PHY6B17 (P/R)	Core Course XVII: Project Work /Research Methodology and Tour Report		2 1	36	3**	60 15
Total					56	1350

* Exam will be held at the end of 4th semester

** Exam will be held at the end of 6th semester

***An institution can choose any one among the three courses.

CORE COURSE THEORY: EVALUATION SCHEME

The evaluation scheme for each course contains two parts: viz., internal evaluation and external evaluation. Maximum marks from each unit are prescribed in the syllabus.

1. INTERNAL EVALUATION

20% of the total marks in each course are for internal evaluation. The colleges shall send only the marks obtained for internal examination to the university.

Table 1: Components of Evaluation (Theory)

<i>Sl. No.</i>	<i>Components</i>	<i>Marks for 4/5 credits papers</i>	<i>Marks for 2/3 credits papers</i>
1	Class room participation based on attendance	4	3
2	Test paper: I	8	6
3	Assignment	4	3
4	Seminar/ Viva	4	3
<i>Total Marks</i>		20	15

Table 2: Pattern of Test Papers

<i>Duration</i>	<i>Pattern</i>	<i>Total number of questions</i>	<i>Number of questions to be answered</i>	<i>Marks for each question</i>	<i>Marks</i>
2 Hours	Short answer	12	10-12	2	20
	Paragraph/problem	7	6-7	5	30
	Essay	2	1	10	10
<i>Total Marks*</i>					60

*90% and above = 6, 80 to below 90% = 5.5, 70 to below 80% = 5, 60 to below 70% = 4.5, 50 to below 60% = 4, 40 to below 50% = 3.5, 35 to below 40% = 3, 25 to below 30% = 2.5, 15 to below 20 = 2, less than 15 = 0

2. EXTERNAL EVALUATION

External evaluation carries 80% marks. University examinations will be conducted at the end of each semester.

Table 1: Pattern of Question Paper

<i>Duration</i>	<i>Pattern</i>	<i>Total number of questions</i>	<i>Number of questions to be answered</i>	<i>Marks for each question</i>	<i>Marks</i>
2 Hours	Short answer	12	10-12	2	20
	Paragraph/problem	7	6-7	5	30
	Essay	2	1	10	10

CORE COURSE PROJECT: EVALUATION SCHEME

Project evaluation will be conducted at the end of sixth semester.

Project:

1. Project work should be done as an extension of topics in the syllabus.
2. Project can be experimental / theoretical or done in collaboration (association) with a recognized laboratory or organization.
3. Project work may be done individually or as group of maximum of six students.
4. A supervisor has to guide a batch of maximum 24 students. For an additional batch another supervisor has to be appointed. However the existing work load should be maintained.

Guidelines for doing project:

The project work provides the opportunity to study a topic in depth that has been chosen or which has been suggested by a staff member. The students first carryout a literature survey which will provide the background information necessary for the investigations during the research phase of the project.

The various steps in project works are the following:-

- a) Wide review of a topic.
- b) Investigation on an area of Physics in systematic way using appropriate techniques.
- c) Systematic recording of the work.
- d) Reporting the results with interpretation in documented and oral forms.

Use of Log Book

- During the Project the students should make regular and detailed entries in to a personal laboratory log book through the period of investigation.
- The log book will be a record of progress on project and will be useful in writing the final report. It contains experimental conditions and results, ideas, mathematical expressions, rough work and calculation, computer file names etc. All entries should be dated.
- The students are expected to have regular meeting with their supervisor to discuss progress on the project and the supervisor should regularly write brief comments with dated signature.
- **The log book and the written report must be submitted at the end of the project.**

Table 1: Internal Evaluation

<i>Sl. No</i>	<i>Criteria</i>	<i>Marks</i>
1	Punctuality & Log book	2
2	Skill in doing project work/data	2
3	Scheme Organization of Project Report	3
4	Viva-Voce	5
<i>Total Marks</i>		12

Table 2: External Evaluation

Individual presentation is compulsory and individual Log book should be submitted

<i>Sl. No</i>	<i>Criteria</i>	<i>Marks</i>
1	Content and relevance of the project, Methodology, Reference, Bibliography	8
2	Project Presentation, Quality of analysis, statistical tools, findings, recommendations	10
3	Project Report (written copy) and Log Book	10
4	Viva-voce	20
<i>Total Marks</i>		48

STUDY TOUR Internal 5 marks

Minimum two days visit to National research Institutes, Laboratories and places of scientific importance are mandatory. Study tour report has to be submitted with photos and analysis along with Practical Paper III for evaluation

Distribution of marks EXTERNAL

No	Items	External (15)
1	Documented Report	8
2	Outcome/Analysis	4
3	Photos (five photos)	3
TOTAL		15

CORE COURSE: PRACTICAL EVALUATION SCHEME

Internal		External		Marks for Python Programming
Items	Marks	Items	Marks	
Record	4	Record with 20 experiments Max one mark for each experiment	10	10
Regularity in doing the experiment	4	Formulae, Theory, Principle/ Programme	22	15
Attendance	4	Adjustments & setting / Algorithm	14	15
Test 1	4	Tabulation, Observation and performance/ Execution	20	24
Test 2	4	Calculation, result, graph, unit/ Result	10	12
		Viva	4	4
Total	20	Total	80	80

CORE COURSE – XIII (ELECTIVE) :		
1	PHY6 B14 (EL1)	BIOMEDICAL PHYSICS
2	PHY6 B14 (EL2)	NANO SCIENCE AND TECHNOLOGY
3	PHY6 B14 (EL3)	MATERIALS SCIENCE

OPEN COURSES OFFERED BY PHYSICS DEPARTMENT (For students from other streams)		
1	PHY5 D01(1)	NON CONVENTIONAL ENERGY SOURCES
2	PHY5 D01(2)	AMATEUR ASTRONOMY AND ASTROPHYSICS
3	PHY5 D01(3)	ELEMENTARY MEDICAL PHYSICS

PHYSICS COMPLEMENTARY COURSE STRUCTURE

Total Credits: 12 (Internal: 20%; External: 80%)

<i>Semester</i>	<i>Code No</i>	<i>Course Title</i>	<i>Hours/Week</i>	<i>Total Hours</i>	<i>Credit</i>	<i>Marks</i>
1	PHY1C01	Complementary Course I: Properties of matter and Thermodynamics	2	36	2	75
	-	Complementary Course V: PHYSICS Practical	2	36	.*	-
2	PHY2C02	Complementary Course II: Optics ,Laser, Electronics	2	36	2	75
	-	Complementary Course V: PHYSICS Practical	2	36	.*	-
3	PHY3C03	Complementary Course III: Mechanics, Relativity, Waves and Oscillations	3	54	2	75
	-	Complementary Course V: PHYSICS Practical	2	36	.*	-
4	PHY4C04	Complementary Course IV: Electricity ,Magnetism and Nuclear Physics	3	54	2	75
	PHY4C05	Complementary Course V: PHYSICS Practical	2	36	4*	100
Total					12	400

* Examination will be held at the end of 4th semester

COMPLEMENTARY COURSE THEORY: EVALUATION SCHEME

The evaluation scheme for each course contains two parts: viz., internal evaluation and external evaluation. Maximum marks from each unit are prescribed in the syllabus.

1. INTERNAL EVALUATION

20% of the total marks in each course are for internal evaluation. The colleges shall send only the marks obtained for internal examination to the university.

Table 1: Components of Evaluation

<i>Sl. No.</i>	<i>Components</i>	<i>Marks for 2/3 credits papers</i>
1	Class room participation based on attendance	3
2	Test paper: I	6
3	Assignment	3
4	Seminar/ Viva	3
<i>Total Marks</i>		15

Table 2: Pattern of Test Papers

<i>Duration</i>	<i>Pattern</i>	<i>Total number of questions</i>	<i>Number of questions to be answered</i>	<i>Marks for each question</i>	<i>Marks</i>
2 Hours	Short answer	12	10-12	2	20
	Paragraph/problem	7	6-7	5	30
	Essay	2	1	10	10
<i>Total Marks*</i>					60

*90% and above = 6, 80 to below 90% = 5.5, 70 to below 80% = 5, 60 to below 70% = 4.5, 50 to below 60% = 4, 40 to below 50% = 3.5, 35 to below 40% = 3, 25 to below 30% = 2.5, 15 to below 20 = 2, less than 15 = 0

2. EXTERNAL EVALUATION

External evaluation carries 80% marks. University examinations will be conducted at the end of each semester.

Table 1: Pattern of Question Papers

<i>Duration</i>	<i>Pattern</i>	<i>Total number of questions</i>	<i>Number of questions to be answered</i>	<i>Marks for each question</i>	<i>Marks</i>
2 Hours	Short answer	12	10-12	2	20
	Paragraph/problem	7	6-7	5	30
	Essay	2	1	10	10
<i>Total Marks</i>					60

Practical Evaluation (Complementary)

Internal		External	
Record	4	Record with 20 experiments. Max. ½ mark for one expt.	10
Regularity	4	Formulae, Theory, Principle	22
Attendance	4	Adjustments, setting	14
Test I	4	Tabulation & Observation	20
Test II	4	Calculation, graph, result, unit	10
		Viva	4
Total	20	Total	80

OPEN COURSE STRUCTURE
(FOR STUDENTS OTHER THAN B.Sc. Physics)
Total Credits: 2 (Internal 20%; External 80%)

<i>Semester</i>	<i>Code No</i>	<i>Course Title</i>	<i>Hours/Week</i>	<i>Total Hours</i>	<i>Marks</i>
5	PHY5D01(1)	Open Course 1: Non conventional Energy Sources	3	54	75
	PHY5D01(2)	Open Course 2: Amateur Astronomy and Astrophysics			
	PHY5D01(3)	Open Course 3: Elements of Medical Physics			

OPEN COURSE: EVALUATION SCHEME

The evaluation scheme contains two parts: viz., internal evaluation and external evaluation.
Maximum marks from each unit are prescribed in the syllabus.

Problems are not required

1. INTERNAL EVALUATION

20% of the total marks are for internal evaluation. The colleges shall send only the marks obtained for internal examination to the university.

Table 1: Components of Evaluation

<i>Sl. No.</i>	<i>Components</i>	<i>Marks for 2/3 credits papers</i>
1	Class room participation based on attendance	3
2	Test paper: I	6
3	Assignment	3
4	Seminar/ Viva	3
<i>Total Marks*</i>		15

Table 2: Pattern of Test Papers (Internal)

<i>Duration</i>	<i>Pattern</i>	<i>Total number of questions</i>	<i>Number of questions to be answered</i>	<i>Marks for each question</i>	<i>Marks</i>
2 Hours	Short answer	12	10-12	2	20
	Paragraph/problem	7	6-7	5	30
	Essay	2	1	10	10
<i>Total Marks*</i>					60

*90% and above = 6, 80 to below 90% = 5.5, 70 to below 80% = 5, 60 to below 70% = 4.5, 50 to below 60% = 4, 40 to below 50% = 3.5, 35 to below 40% = 3, 25 to below 30% = 2.5, 15 to below 20 = 2, less than 15 = 0

2. EXTERNAL EVALUATION

External evaluation carries 80% marks. University examination will be conducted at the end of 5th semester.

Table 1: Pattern of Question Paper

<i>Duration</i>	<i>Pattern</i>	<i>Total number of questions</i>	<i>Number of questions to be answered</i>	<i>Marks for each question</i>	<i>Marks</i>
2 Hours	Short answer	12	10-12	2	20
	Paragraph/problem	7	6-7	5	30
	Essay	2	1	10	10
<i>Total Marks</i>					60

B.Sc. PHYSICS
CORE PROGRAMMES SYLLABUS

Core Course I
PHY1 B01: MECHANICS – I
36 hours (Credit - 2)

	Course Outcome	PSO	CL	KC	Class Sessions Allotted
C01	Understand and apply the basic concepts of Newtonian Mechanics to Physical Systems	PSO1	Ap	C,P	16
C02	Understand and apply the basic idea of work-energy theorem to physical systems	PSO1	Ap	C,P	8
C03	Understand and apply the rotational dynamics of rigid bodies	PSO1	Ap	C,P	12

Unit I– Newton’s Laws

16 Hrs

Newton’s First Law, Second Law and Third Law – Astronauts in space : Inertial systems and fictitious forces – Standards and units – Some applications of Newton’s laws – The astronauts’ tug of war, Freight train, Constraints, Block on string, The whirling block, The conical pendulum – The everyday forces of physics – Gravity and Weight; Gravitational force of a sphere; Turtle in an elevator; Gravitational field – Electrostatic force – Contact forces; Block and string; Dangling rope; Whirling rope; Pulleys; Tension and Atomic forces; Normal force; Friction; Block and wedge with friction; Viscosity – Linear restoring force; Spring and block : The equation for simple harmonic motion; Spring and gun : Illustration of initial conditions – Dynamics of a system of particles – The Bola – Centre of mass – Drum major’s baton – Centre of mass motion – Conservation of momentum – Spring Gun recoil

[Sections 2.1 to 2.5, 3.1 to 3.3 of An Introduction to Mechanics (1stEdn.) by Daniel Kleppner and Robert J. Kolenkow]

Unit II – Work and Energy

8 Hrs

Integrating the equation of motion in one dimension – Mass thrown upward in a uniform gravitational field; Solving the equation of simple harmonic motion – Work-energy theorem in one dimension – Vertical motion in an inverse square field – Integrating the equation of motion in several dimensions – Work-energy theorem – Conical pendulum; Escape velocity – Applying the work-energy theorem – Work done by a uniform force; Work done by a central force; Potential energy – Potential energy of a uniform force field; Potential energy of an inverse square force – What potential energy tells us about force – Stability – Energy diagrams – Small oscillations in a bound system – Molecular vibrations – Nonconservative forces – General law of conservation of energy – Power

[Sections 4.1 to 4.13 of An Introduction to Mechanics (1stEdn.) by Daniel Kleppner and Robert J. Kolenkow. The problems in chapter 5 should be discussed with this.]

Unit III – Angular Momentum**12 Hrs**

Angular momentum of a particle – Angular momentum of a sliding block; Angular momentum of the conical pendulum – Torque – Central force motion and the law of equal areas – Torque on a sliding block; Torque on the conical pendulum; Torque due to gravity – Angular momentum and fixed axis rotation – Moments of inertia of some simple objects – The parallel axis theorem – Dynamics of pure rotation about an axis – Atwood’s machine with a massive pulley – The simple pendulum – The physical pendulum – Motion involving both translation and rotation – Angular momentum of a rolling wheel – Drum rolling down a plane – Work-energy theorem for a rigid body – Drum rolling down a plane : energy method – The vector nature of angular velocity and angular momentum – Rotation through finite angles – Rotation in the xy-plane – Vector nature of angular velocity – Conservation of angular momentum

[Sections 6.1 to 6.7, 7.1, 7.2 and 7.5 of An Introduction to Mechanics (1stEdn.) by Daniel Kleppner and Robert J. Kolenkow]

Books of Study :

1. An Introduction to Mechanics, 1stEdn. – Daniel Kleppner and Robert J. Kolenkow – McGraw-Hill

Reference Books :

1. Berkeley Physics Course : Vol.1 : Mechanics, 2ndEdn. – Kittel *et al.* – McGraw-Hill

Mark Distribution for Setting Question Paper

Unit/ Chapter	Title	Marks
1	Newton’s laws	36
2	Work and Energy	18
3	Angular Momentum	25
<i>Total Marks*</i>		79

*Total marks include that for choice of questions in sections A, B and C in the question paper.

Semester 2 | Core Course II
PHY 2 B02: MECHANICS – II
36 hours (Credit - 2)

	Course Outcome	PSO	CL	KC	Class Sessions Allotted
C01	Understand the features of non-inertial systems and fictitious forces	PSO1	U	C	8
C02	Understand and analyze the features of central forces with respect to planetary forces	PSO1	An	C,P	10
C03	Understand the basic ideas of Harmonic Oscillations	PSO1	U	C	8
C04	Understand the analyze the basic concepts of wave motion	PSO1	An	C,P	10

Unit I – Noninertial Systems and Fictitious Forces

8 Hrs

Galilean transformations – Uniformly accelerating systems – The apparent force of gravity – Pendulum in an accelerating car – The principle of equivalence – The driving force of the tides – Physics in a rotating coordinate system – Time derivatives and rotating coordinates – Acceleration relative to rotating coordinates – The apparent force in a rotating coordinate system – The Coriolis force – Deflection of a falling mass – Motion on the rotating earth – Weather systems – Foucault's pendulum

[Sections 8.1 to 8.5 of *An Introduction to Mechanics* (1stEdn.) by Daniel Kleppner and Robert J. Kolenkow]

Unit II – Central Force Motion

10 Hrs

Central force motion as a one-body problem – General properties of central force motion – Motion is confined to a plane – Energy and angular momentum are constants of the motion – The law of equal areas – Finding the motion in real problems – The energy equation and energy diagrams – Noninteracting particles – Planetary motion – Hyperbolic orbits – Satellite orbit – Kepler's laws – The law of periods – Properties of the ellipse

[Sections 9.1 to 9.7 of *An Introduction to Mechanics* (1stEdn.) by Daniel Kleppner and Robert J. Kolenkow]

Unit III – Harmonic Oscillator

8 Hrs

Introduction and review – Standard form of the solution – Nomenclature – Initial conditions and the frictionless harmonic oscillator – Energy considerations – Time average values – Average energy – Damped harmonic oscillator – Energy and Q-factor – Q factor of two simple oscillators

– Graphical analysis of a damped oscillator – Solution of the equation of motion for the undriven damped oscillator – Forced harmonic oscillator – Undamped forced oscillator – Resonance
 [Sections 10.1 to 10.3 (except the topic, *The Forced Damped Harmonic Oscillator*) and Note 10.1 of An Introduction to Mechanics (1stEdn.) by Daniel Kleppner and Robert J. Kolenkow]

Unit IV – Waves

10Hrs

What is a wave ? – Normal modes and travelling waves – Progressive waves in one direction – Wave speeds in specific media – Superposition – Wave pulses – Motion of wave pulses of constant shape – Superposition of wave pulses – Dispersion; Phase and Group Velocities – Energy in a mechanical wave – Transport of energy by a wave – Momentum flow and mechanical radiation pressure – Waves in two and three dimensions

[Chapter 7 – Progressive Waves (except the topic, *The Phenomenon of Cut-off*) of Vibrations and Waves by A. P. French]

Books of Study :

1. An Introduction to Mechanics, 1stEdn. – Daniel Kleppner and Robert J. Kolenkow – McGraw-Hill
2. Vibrations and Waves – A. P. French – The M.I.T. Introductory Physics Series – CBS Publishers & Distributors

Reference Books :

1. Berkeley Physics Course : Vol.1 : Mechanics, 2ndEdn. – Kittel *et al.* – McGraw-Hill

Unit/ Chapter	Title	Marks
1	Non-inertial systems and fictitious forces	18
2	Central force motion	22
3	Harmonic Oscillator	18
4	Waves	21
<i>Total Marks*</i>		79

*Total marks include that for choice of questions in sections A, B and C in the question paper.

Semester 3 | Core Course III
PHY3B03: ELECTRODYNAMICS I
54 hours (Credit - 3)

	Course Outcome	PSO	CL	KC	Class Sessions allotted
CO1	Understand and apply the fundamentals of vector calculus	PSO1	Ap	C	10
CO2	Understand and analyze the electrostatic properties of physical systems	PSO1	An	C, P	16
CO3	Understand the mechanism of electric field in matter.	PSO1	U	C,P	8
CO4	Understand and analyze the magnetic properties of physical systems	PSO1	An	C,P	12
CO5	Understand the mechanism of magnetic field in matter.	PSO1	U	C,P	8

Unit 1 – Vector Calculus

10 Hrs

Vector Algebra: Vector operations - Vector algebra: Component form – Triple products – Position, Displacement and Separation vectors – How vectors transform. Differential Calculus: “Ordinary” derivatives – Gradient – The Del operator – Divergence – Curl – Product rules – Second derivatives. Integral Calculus: Line integral, surface integral and volume integral – Fundamental theorem of calculus – Fundamental theorem for Gradients – Fundamental theorem for divergences: Gauss’s Divergence Theorem (no proof needed) – Fundamental theorem for curls: Stoke’s theorem (no proof needed). Spherical polar coordinates – Cylindrical coordinates – Their relationship to Cartesian coordinates – Expressing differential displacement vector, differential area vectors, differential volume element, gradient operator, divergence operator and curl operator in spherical polar and cylindrical coordinates. Dirac delta function: Divergence of $\frac{\mathbf{r}^n}{r^2}$ – One-dimensional delta function – Three-dimensional delta function. Helmholtz theorem (no proof needed) – Divergence-less vector fields – Curl-less vector fields – Potentials.

[Sections 1.1 to 1.6 of Introduction to Electrodynamics (4th Edn.) by David J Griffiths.]

Unit 2 – Electrostatics

16 Hrs

Electrostatic field – Coulomb’s law, Electric field, Continuous charge distributions - Divergence and curl of electrostatic field, Field lines and Gauss’s law, The divergence of \mathbf{E} , Applications of Gauss law, Curl of \mathbf{E} – Electric potential – Comments on potential, Poisson’s equation and Laplace’s equation, The potential of a localized charge distribution, Electrostatic boundary

conditions – Work and energy in electrostatics, The work done in moving a charge, The energy of point charge distribution, The Energy of a continuous charge distribution, Comments on Electrostatic energy – Conductors, Basic properties of conductors, Induced charges, The Surface charge on a conductor, The force on surface charge, Capacitors.

[Sections 2.1 to 2.5 of Introduction to Electrodynamics by David J Griffiths. Additional problems should be done from chapters 1, 2 and 3 of Berkeley Physics Course: Vol.2: Electricity and Magnetism (2nd Edn.) by Edward M Purcell.]

Unit 3 – Electric fields in matter

8 Hrs

Polarization – Dielectrics, Induced dipoles, Alignment of polar molecules, Polarization – The field of a polarized object, Bound charges, Physical interpretation of bound charges, The field inside a dielectric – The electric displacement – Gauss's law in presence of dielectrics, Boundary conditions for \mathbf{D} – Linear dielectrics, Susceptibility, Permittivity, Dielectric constant, Boundary value problems with linear dielectrics, Energy in dielectric systems, Forces on dielectrics.

[Sections 4.1 to 4.4 of Introduction to Electrodynamics (4th Edn.) by David J Griffiths. Additional problems should be done from chapter 10 of Berkeley Physics Course: Vol.2: Electricity and Magnetism (2nd Edn.) by Edward M Purcell.]

Unit 4 – Magnetostatics

12 Hrs

The Lorentz force law – Magnetic fields, Magnetic forces, cyclotron motion, cycloid motion, Currents, Linear, Surface and Volume current density – Biot -Savart law, The magnetic field of steady current – Divergence and curl of \mathbf{B} , Straight line currents, Applications of Ampere's law, Magnetic field of a toroidal coil, Comparison of magnetostatics and electrostatics – Magnetic vector potential, Vector potential, Magnetostatic boundary conditions.

[Sections 5.1 to 5.4.2 of Introduction to Electrodynamics (4th Edn.) by David J Griffiths. Additional problems should be done from chapter 6 of Berkeley Physics Course: Vol.2: Electricity and Magnetism (2nd Edn.) by Edward M Purcell.]

Unit 5 – Magnetostatic fields in matter

8 Hrs

Magnetization – Diamagnets, Paramagnets and Ferromagnets, Torques and forces on magnetic dipoles, Effect of a magnetic field on atomic orbits, Magnetization – Field of a magnetised object, Bound Currents, Physical interpretation of bound currents, Magnetic field inside matter – Auxiliary field \mathbf{H} , Ampere's law in magnetized materials, Boundary conditions – Linear and nonlinear media, Magnetic susceptibility and permeability, Ferromagnetism.

[Sections 6.1 to 6.4 of Introduction to Electrodynamics (4th Edn.) by David J Griffiths. Additional problems should be done from chapter 11 of Berkeley Physics Course: Vol.2: Electricity and Magnetism (2nd Edn.) by Edward M Purcell.]

Books of Study:

1. Introduction to Electrodynamics, 4th Edn. – David J Griffiths – Prentice Hall India Learning Pvt. Ltd
2. Berkeley Physics Course: Vol.2: Electricity and Magnetism, 2nd Edn. – Edward M. Purcell – McGraw-Hill

Reference Books:

1. Electricity and magnetism by Arthur F Kip
2. Physics Vol. II by Resnick and Halliday
3. Electricity and Magnetism-Hugh D Young and Roger A Freedman
4. Vector Analysis M R Spiegel,S Lipschutz,D Spellman -Schaum’s outline-McGraw Hill
5. Div, Grad, Curl and all that ; An informal text on vector calculus H M Schey (Norton)
6. Electromagnetics by Edminister – Schaum’s Outline – Tata McGraw Hill
7. NPTEL video lectures available online

Mark distribution for setting Question paper.

Unit/ chapter	Title	Marks
1	Vector Calculus	15
2	Electrostatics	22
3	Electric fields in matter	12
4	Magnetostatics	18
5	Magnetostatic fields in matter	12
<i>Total Marks *</i>		79

*Total marks include that for choice of questions in sections A, B and C in the question paper.

Semester 4 | Core Course IV
PHY4B04: ELECTRODYNAMICS II
54 Hours (Credit - 3)

	Course Outcome	PSO	CL	KC	Class Sessions allotted
CO1	Understand the basic concepts of electrodynamics	PSO1	U	C	15
CO2	Understand and analyze the properties of electromagnetic waves	PSO1	An	C, P	15
CO3	Understand the behavior of transient currents	PSO1	U	C	8
CO4	Understand the basic aspects of ac circuits	PSO1	An	C,P	8
CO5	Understand and apply electrical network theorems	PSO1	Ap	C,P	8

Unit 1 – Electrodynamics

15 Hrs

Electromotive force – Ohm’s law, electromotive force, motional emf – Electromagnetic induction – Faraday’s law, induced electric field, inductance, energy in magnetic fields – Maxwell’s equations – Electrodynamics before Maxwell, Maxwell’s modification of Ampere’s law, Maxwell’s equations, Magnetic charge, Maxwell’s equations inside matter, Boundary conditions – Continuity equation – Poynting’s theorem

[Sections 7.1 to 7.3 and 8.1 of Introduction to Electrodynamics by David J Griffiths. Additional problems should be done from chapter 7 of Berkeley Physics Course: Vol.2: Electricity and Magnetism (2nd Edn.) by Edward M Purcell.]

Unit 2 – Electromagnetic waves

15 Hrs

Waves in one dimension, The wave equation, sinusoidal waves, boundary conditions :reflection and transmission, Polarization – Electromagnetic waves in vacuum , Wave equation for **E** and **B**, monochromatic plane waves in vacuum, energy and momentum of E.M. waves, Poynting vector - Electromagnetic waves in matter, Propagation through linear media, reflection and transmission at normal incidence. Potential formulation – Scalar and vector potentials, Gauge transformations, Coulomb gauge and Lorentz gauge.

[Sections 9.1 to 9.3.2 and 10.1 of Introduction to Electrodynamics by David J Griffiths. Additional problems should be done from chapter 9 of Berkeley Physics Course: Vol.2: Electricity and Magnetism (2nd Edn.) by Edward M Purcell.]

Unit 3 – Transient currents**8 Hrs**

Types of transients – DC transient currents in R-L circuits – Short circuit current – Time constant – DC transient currents in R-C circuits – Double energy transients – Theory of BG

[Sections 22.1, 22.2, 22.4, 22.5, 22.6, 22.8, 22.10 and 10.52 of Electrical Technology Vol. 1 by B. L. Theraja and A. K. Theraja]

Unit 4 – AC circuits**8 Hrs**

A resonant circuit – Alternating current – Alternating current networks – Admittance and impedance – Power and energy in AC circuits

[Sections 8.1 to 8.5 of Berkeley Physics Course: Vol.2: Electricity and Magnetism (2nd Edn.) by Edward M Purcell. Additional problems should be done from the relevant sections from chapters 13 and 14 of the book of Electrical Technology Vol. 1 by B. L. Theraja and A. K. Theraja]

Unit 5 – Network theorems**8 Hrs**

Kirchhoff's laws, Voltage sign and current direction, Solution of simultaneous equations using determinants, Source conversion, Superposition theorem, Ideal equivalent circuits, Thevenin's theorem, Reciprocity theorem, Delta / Star transformation – Star / Delta transformation – Norton's theorem, Maximum power transfer theorem.

[Sections 2.2 to 2.6, 2.14 to 2.23, 2.25, 2.26, 2.27 and 2.30 from Electrical Technology Vol. 1 by B. L. Theraja and A. K. Theraja]

Books of Study :

1. Introduction to Electrodynamics, 4th Edn. – David J Griffiths – Prentice Hall India Learning Pvt. Ltd
2. Berkeley Physics Course: Vol.2: Electricity and Magnetism, 2nd Edn. – Edward M. Purcell – McGraw-Hill
3. A Text Book of Electrical Technology Vol. 1 – B. L. Theraja, A. K. Theraja – S. Chand Publishers, 1997

Reference Books :

1. Electricity and magnetism by Arthur F Kip
2. Physics Vol. II by Resnick and Halliday
3. Electricity and Magnetism by D.N Vasudeva (12th revised edition)
4. Introductory AC Circuit theory – K Mann & G J Russell- Universities Press
5. NPTEL video lectures available online

Mark distribution for setting Question paper.

Unit/ chapter	Title	Marks
1	Electrodynamics	22
2	Electromagnetic waves	22
3	Transient currents	12
4	AC circuits	12
5	Network theorems	11
<i>Total Marks *</i>		79

*Total marks include that for choice of questions in sections A, B and C in the question paper.

Semester 5 Core Course –VI
PHY5B06: COMPUTATIONAL PHYSICS
54 Hours (Credit – 3)

	Course Outcome	PSO	CL	KC	Class Sessions allotted
CO1	Understand the Basics of Python programming	PSO4	U	C	14
CO2	Understand the applications of Python modules	PSO4	U	C	8
CO3	Understand the basic techniques of numerical analysis	PSO4	U	C	18
CO4	Understand and apply computational techniques to physical problems	PSO4	Ap	C,P	14

Unit 1

Chapter 1: Introduction to Python Programming

16 Hrs

Introduction to algorithm, flowchart and high level Computer programming languages Compilers- Interpreters - Introduction to Python language- Advantages and unique features of Python language - Interactive mode and script mode- Writing and execution of programs -various data types in Python- Reading keyboard input: The raw_input function and input function - print command, formatted printing- open and write function - Variables, operators, expressions and statements- String operations, Lists, list operations (len, append, insert, del, remove, reverse, sort, +, *, max, min, count, in, not in, sum), sets, set operations (set, add, remove, in, not in, union, intersection, symmetric difference)-Tuples and Dictionaries, various control and looping statements: (if, if..else, if..elif, while, for, break, continue) - user defined functions- Modules - File input and file output- Pickling.

Books for study:

- 1.Introduction to Python for Engineers and Scientists by Dr.Sandeep Nagar, Apress publications.
- 2.Python for Education by Dr. B P Ajithkumar, IUAC, New Delhi; e-book freely downloadable from www.expeyes.in/documents/mapy.pdf
3. Python Tutorial Release 3.0.1 by Guido van Rossum, Fred L. Drake, Jr., editor. (<http://www.altaway.com/resources/python/tutorial.pdf>)

Chapter 2: Numpy and Matplotlib modules**6 Hrs**

Numpy module: Introduction, creation of arrays and matrices, various array operations, matrix multiplication, inversion. Matplotlib module: Introduction, plot(), show() functions, syntax for plotting graphs , multiple plots, polar plots, labeling, scaling of axes and coloring plots - Plotting of functions – $\sin(x)$, $\cos(x)$, $\exp(x)$, $\sin^2(x)$, $\sin(x^2)$

Books for study:

Python for Education by Dr. B P Ajithkumar, IUAC, New Delhi; e-book freely downloadable from www.expeyes.in/documents/mapy.pdf

Unit 2**Chapter 3: Numerical Methods in Physics****18 Hrs**

Introduction to numerical methods, Comparison between analytical and numerical methods - Curve Fitting: Principle of least squares, Least square fitting of a straight line -Interpolation: Finite difference operator, Newton's forward difference interpolation formula, difference table, First and second derivative by Numerical differentiation- Solution of algebraic equations: Bisection method, Newton-Raphson method - Newton Cote's quadrature formula- Numerical integration by Trapezoidal and Simpson's (1/3) method- Solution of differential equations: Euler's method, Runge- Kutta method (Second order) -Taylor's Series expansion of $\sin(x)$ and $\cos(x)$.

Books for study:

1. Introductory methods of numerical analysis, S.S.Shastry , (Prentice Hall of India,1983)
2. Python for Education by Dr. B P Ajithkumar, IUAC, New Delhi; e-book freely downloadable from www.expeyes.in/documents/mapy.pdf

Unit 3**Chapter 4: Computational Physics****14 Hrs**

Formulation: From analytical to numerical methods -Significance of Computer in numerical methods- Applications of Euler's method: Theory, and graphical simulation by programming: motions of a freely falling body, a body dropped into a highly viscous medium, two dimensional projectile motion and radioactive decay - Accuracy considerations (elementary ideas)

(All programs should be written using Python language Version 3.0)

Books for study:

1. Computational Physics, V.K.Mittal, R.C.Verma & S.C.Gupta-Published by Ane Books
2. Introductory methods of numerical analysis, S.S.Shastry , (Prentice Hall of India,1983)

3. Introduction to Python for Engineers and Scientists by Dr.Sandeep Nagar, Apress publications.

References:

1. Python for Education by Dr. B P Ajithkumar, IUAC, New Delhi; e-book freely downloadable from www.expeyes.in/documents/mapy.pdf
2. Programming in Python 3: A Complete Introduction to the Python Language by Mark Summerfield-2nd edition-Developer's library
3. Introduction to Python for Engineers and Scientists by Dr.Sandeep Nagar, Apress publications.
4. www.python.org
5. Python Essential Reference, David M. Beazley, Pearson Education
6. Core Python Programming, Wesley J Chun, Pearson Education
7. Python Tutorial Release 3.0.1 by Guido van Rossum, Fred L. Drake, Jr., editor. (<http://www.altaway.com/resources/python/tutorial.pdf>)
8. How to Think Like a Computer Scientist: Learning with Python, Allen Downey , Jeffrey Elkner , Chris Meyers, <http://www.greenteapress.com/thinkpython/thinkpython.pdf>
9. Numerical Methods in Engineering and Science, Dr. B S Grewal, Khanna Publishers, Newdelhi
10. Numerical methods for scientists and engineers, K. Sankara Rao, PHI
11. Introductory methods of numerical analysis, S.S.Shastry , (Prentice Hall of India,1983)
12. Computational Physics, V.K.Mittal, R.C.Verma & S.C.Gupta-Published by Ane Books

Mark distribution for setting Question paper.

Unit/ chapter	Title	Marks
1	Introduction to Python Programmming	23
2	Numpy and Matplotlib modules	10
3	Numerical Methods in Physics	26
4	Computational Physics	20
<i>Total Marks *</i>		79

*Total marks include that for choice of questions in sections A, B and C in the question paper.

Semester 5 Core Course –VII
PHYSB07: QUANTUM MECHANICS

54 Hours (Credit – 3)

	Course Outcome	PSO	CL	KC	Class Sessions allotted
CO1	Understand the particle properties of electromagnetic radiation	PSO2	U	C	8
CO2	Describe Rutherford – Bohr model of the atom	PSO2	U	C	10
CO3	Understand the wavelike properties of particles	PSO2	U	C	10
CO4	Understand and apply the Schrödinger equation to simple physical systems	PSO2	Ap	C,P	16
CO5	Apply the principles of wave mechanics to the Hydrogen atom	PSO2	Ap	C,P	10

Unit 1

1. Particle like Properties of Electromagnetic Radiation 8 Hrs

Review of electromagnetic waves – Photoelectric effect – Blackbody radiation – Compton effect – Other photon processes – What is a photon?

[Sections 3.1 to 3.6 of Modern Physics by Kenneth Krane]

2. Rutherford-Bohr Model of the Atom 10 Hrs

Basic properties of atoms – Thomson model – Rutherford nuclear atom – Line spectra – Bohr model – Frank-Hertz experiment – Correspondence principle – Deficiencies of Bohr model

[Sections 6.1 to 6.8 of Modern Physics by Kenneth Krane]

Unit 2

3. Wavelike Properties of Particles 10 Hrs

De Broglie hypothesis - Uncertainty relationships for classical waves – Heisenberg uncertainty relationships – Wave packets - Probability and randomness – Probability amplitude

[Sections 4.1 to 4.6 of Modern Physics by Kenneth Krane]

Unit 3

4. The Schrodinger Equation 16 Hrs

Justification of the Schrodinger equation – The Schrodinger recipe – Probabilities and normalization – Applications – Free particle, Particle in a box (one dimension), Particle in a box

(two dimensions), Simple harmonic oscillator – Time dependence – Potential energy steps and potential energy barriers

[Sections 5.1 to 5.7 of Modern Physics by Kenneth Krane]

5. Hydrogen Atom in Wave Mechanics

10 Hrs

Schrodinger equation in spherical coordinates – Hydrogen atom wave functions – Radial probability densities – Angular momentum and probability densities – Intrinsic spin – Energy levels and spectroscopic notation – Zeeman effect – Fine structure

[Sections 7.1 to 7.8 of Modern Physics by Kenneth Krane]

Book of study:

1. Modern Physics, 2nd Edn. – Kenneth S. Krane – John Wiley & sons

Reference Books :

1. Concepts of Modern Physics, 7th Edn. – Arthur Beiser – Tata McGraw-Hill

2. Modern Physics, 3rd Edn. – Raymond A. Serway, Clement J. Moses, Curt A. Moyer – Cengage

3. Quantum Physics of Atoms, Molecules, Solids, Nuclei & Particles By R. Eisberg & R. Resnick - John Wiley

4. Modern Physics, 2ndEdn – Randy Harris – Pearson

5. Modern Physics for Scientists and Engineers, 2ndEdn. – John R. Taylor, Chris D. Zafiratos, Michael A. Dubson – Prentice-Hall of India Pvt. Ltd.

6. Berkeley Physics Course: Quantum Physics by Wichmann

7. Theory and Problems in Modern Physics by Gautreau & Savin – Schaum's Outlines Series – TMH

8. Quantum mechanics: Concepts & Applications by Zetilli N, Second Edition, Wiley

9. NPTEL video lectures available online

Mark distribution for setting Question paper.

Unit/ chapter	Title	Marks
1	Particle like Properties of Electromagnetic Radiation	11
2	Rutherford-Bohr Model of the Atom	15
3	Wavelike Properties of Particles	15
4	The Schrodinger Equation	23
5	Hydrogen Atom in Wave Mechanics	15
<i>Total Marks *</i>		79

*Total marks include that for choice of questions in sections A, B and C in the question paper.

Semester 5 | Core Course VIII

PH5B08: OPTICS

54 Hours (Credit - 3)

	Course Outcome	PSO	CL	KC	Class Sessions allotted
CO1	Understand the fundamentals of Fermat's principles and geometrical optics	PSO2	U	C	5
CO2	Understand and apply the basic ideas of interference of light	PSO2	Ap	C, P	14
CO3	Understand and apply the basic ideas of diffraction of light	PSO2	Ap	C, P	13
CO4	Understand the basic ideas of polarization of light	PSO2	U	C	8
CO5	Describe the basic principles of holography and fibre optics	PSO2	U	C	14

Unit 1

Fermat's Principle, verification of laws of reflection and refraction **2 Hrs**

[Sections 2.1 to 2.6 of Brijlal, Subramaniam, & Avadhanulu and Sections 3.1 to 3.2 of Ajoy Ghatak]

Refraction and reflection by spherical surfaces : **3 Hrs**

Refraction and reflection at a single spherical surfaces. The thin lens, The Principal Foci, and Focal length of a lens, The Newton formula, Lateral magnification.

[Sections 4.1 to 4.7 of Ajoy Ghatak]

Unit 2

2. Interference by division of wave front **6 Hrs**

Superposition of two sinusoidal waves, Interference, coherence ,conditions for interference, the interference patterns, intensity distribution .Fresnel's two mirror arrangement, Fresnel's Biprism, Determination of λ and $d\lambda$ of Sodium Light

[Sections 14.1 to 14.4, 14.6 to 14.9 of Brijlal, Subramaniam, & Avadhanulu, and Sections 14.1 to 14.8 of Ajoy Ghatak. Additional problems should be done from chapter 7 of Introduction to Optics by Frank L. Pedrotti, Leno M Pedrotti and Leno S Pedrotti.]

3. Interference by division of amplitude **8 Hrs**

Interference by a plane film illuminated by a plane wave, cosine law, non reflecting films (the

subsections excluded), interference by a film with two nonparallel reflecting surfaces, colours of thin films, Newton's rings, The Michelson interferometer, white light fringes-

[Sections 15.1 to 15.4,15.7, 15.9, 15.11 of Ajoy Ghatak, and Sections 2.1 to 2.6 of Brijlal, Subramaniyam, & Avadhanulu. Additional problems should be done from chapter 7 of Introduction to Optics by Frank.L,Pedrotti, Leno M Pedrotti and Leno S Pedrotti.]

Unit 3

4. Fraunhofer Diffraction **10 Hrs**

Preliminaries, single slit diffraction pattern, diffraction by circular aperture, limit of resolution, two slit Fraunhofer diffraction pattern, N slit diffraction pattern, plane diffraction grating, resolving power.

[Sections 18.1 to 18.3, 18.5 to 18.8 of Ajoy Ghatak. Additional problems should be done from chapters 11 and 12 of Introduction to Optics by Frank.L,Pedrotti, Leno M Pedrotti and Leno S Pedrotti.]

5. Fresnel Diffraction **3 Hrs**

Preliminaries, Fresnel half period zones, explanation of rectilinear propagation of light, zone plate [Sections 20.1 to 20.3 of Ajoy Ghatak]

Unit 4 **8 Hrs**

6. Polarization

Huygen's explanation of double refraction, positive and negative uniaxial crystals, quarter and half wave plates, types of polarized light, production and analysis of plane, circularly and elliptically polarized light, optical activity, Laurentz half shade polarimeter

[Sections 20.9,20.17 to 20.20,20.24 of Brijlal, Subramaniyam, & Avadhanulu and corresponding sections of Ajoy Ghatak]

Unit 5 **6 Hrs**

7. Holography

Principles of holography, theory of construction and reconstruction of Hologram, Applications of Holography. [Sections 23.1 to 23.6 of Brijlal, Subramaniyam & Avadhanulu and Sections 21.1 to 21.4 of Ajoy Ghatak]

Unit 6 **8 Hrs**

8. Fibre Optics

Optical fibre, Numerical aperture, step index fibre, pulse dispersion, graded index fibre, fibre optic sensors.

[Sections 27.4, 27.7, 27.10, 27.12 of Ajoy Ghatak and corresponding sections from Brijlal, Subramaniam, & Avadhanulu]

Books of study:

1. Optics by Ajoy Ghatak – 4th edition
2. Optics by Subramaniam, Brijlal&Avadhanulu – 2018(Reprint)
3. Introduction to Optics by Frank.L,Pedrotti,Leno M Pedrotti and Leno S Pedrotti

Reference Books :

1. Optics – EugeneHetch and A RGanesan
2. Optics by D S Mathur– New edition
3. Wave Optics and its Applications – Rajpal S Sirohi – Orient Longman
4. Optical Communications – M MukundaRao – Universities Press
5. NPTEL video lectures available online

Mark distribution for setting Question paper.

Unit/ chapter	Title	Marks
1	Fermat's Principle, verification of laws of reflection and refraction Refraction and reflection by spherical surfaces	7
2	Interference by division of wave front	9
3	Interference by division of amplitude	12
4	Fraunhofer Diffraction	15
5	Fresnel Diffraction	4
6	Polarization	12
7	Holography	9
8	Fibre Optics	11
<i>Total Marks *</i>		79

*Total marks include that for choice of questions in sections A, B and C in the question paper.

Semester 5 Core Course –IX
PHYSB09: ELECTRONICS (ANALOG & DIGITAL)
54 Hours (Credit – 3)

	Course Outcome	PSO	CL	KC	Class Sessions allotted
CO1	Understand the basic principles of rectifiers and dc power supplies	PSO3	U	C	6
CO2	Understand the principles of transistor	PSO3	U	C	14
CO3	Understand the working and designing of transistor amplifiers and oscillators	PSO3	Ap	C, P	12
CO4	Understand the basic operation of Op – Amp and its applications	PSO3	U	C	6
CO5	Understand the basics of digital electronics	PSO3	U	C	16

Unit 1

1. Semiconductor rectifiers and DC Power supplies 6 Hrs

Preliminaries of rectification- Bridge rectifier- Efficiency- Nature of rectified output- Ripple factor- different types of filter circuits- voltage multipliers- Zener diode- voltage stabilization

[Sections 6.13-6.15, 6.17 - 6.27 of V.K Mehta]

2. Transistors 14 Hrs

Different transistor amplifier configurations:- CB, CE, CC and their characteristics- amplification factors- their relationships- Load line Analysis- Expressions for voltage gain- current gain and power gain of C.E amplifier- cut-off and saturation points- Transistor biasing- Different types of biasing - Base resistor, voltage divider bias method- single stage transistor amplifier circuit- load line analysis- DC and AC equivalent circuits

[Section 8.7 - 8.10, 8.12-8.22, 9.2-9.8, 9.11-9.12, 10.4-10.5, 10.7-10.9 of V K Mehta]

Unit 2

3. Multistage Transistor amplifiers 4 Hrs

R.C coupled amplifier- frequency response and gain in decibels- Transformer coupled Amplifiers -Direct Coupled Amplifier-Comparison [Section 11.1-11.8 of VK Mehta]

4. Feedback Circuits and Oscillators 8 Hrs

Basic principles of feedback- negative feedback and its advantages- positive feedback circuits- Oscillatory Circuits-LC, RC oscillators- tuned collector oscillator- Hartley, Colpitt's, phase shift

oscillators - their expressions for frequency [Sections 13.1-13.5, 14.1 - 14.13 of VK Mehta]

5. Operational amplifier and its applications

6 Hrs

Differential amplifier (basic ideas only), OP-amp: basic operation, application, inverting, Non-inverting, summing amplifiers, Differentiator integrator [Sections 25.1 – 25.5, 25.16, 25.15-25.17, 25.23-25.26, 25.32, 25.34-25.35, 25.37 of VK Mehta]

Unit 3

6. Number systems

6 Hrs

Binary number system, conversions from one system to another (Binary, octal, Hexa decimal), Binary arithmetic, Compliments and its algebra.
(Sections - 2.2 to 2.8 of Aditya P Mathur).

7. Logic gates and circuits

10 Hrs

Fundamental gates, Universal gates, De Morgan's theorem, Exclusive OR gate, Boolean relations, Half adder, Full adder, RS Flip Flop, JK Flip flop

[Sections - 2.2 to 2.4, 3.1 to 3.5, 5.1 to 5.6, 6.3, 6.4, 7.1, 7.3, 7.5, 7.6, 8.2 Malvino & Leach]

Text books for study :

1. Principles of electronics - VK Mehta - 2008 edition (S. Chand)
2. Introduction to Micro Processors - Aditya P Mathur (Tata McGraw Hill)
3. Digital principles and applications - Leach and Malvino (Tata McGraw Hill)

References

1. Electronic Principles by Malvino - (Tata McGraw Hill)
2. Digital Computer Fundamentals (Thomas. C. Bartee)
3. Physics of Semiconductor Devices- Second Edition – Dilip K Roy – Universities Press
4. Digital Fundamentals –Thomas L Floyd – Pearson Education
5. The Art of Electronics-Paul Herowitz & Winfield Hill
6. Digital Technology – Principles and practice by Virendrakumar
7. Electronic Principles and Applications – A B Bhattacharya
8. NPTEL video lectures available online

Mark distribution for setting Question paper.

Unit/ chapter	Title	Marks
1	Semiconductor rectifiers and DC Power supplies	9
2	Transistors	20
3	Multistage Transistor amplifiers	6
4	Feedback Circuits and Oscillators	12
5	Operational amplifier and its applications	9
6	Number systems	9
7	Logic gates and circuits	14
<i>Total Marks *</i>		79

*Total marks include that for choice of questions in sections A, B and C in the question paper.

Semester 6 | Core Course X
PHY6B10: THERMODYNAMICS
54 Hours (Credit - 3)

	Course Outcome	PSO	CL	KC	Class Sessions allotted
CO1	Understand the zero and first laws of thermodynamics	PSO2	U	C	14
CO2	Understand the thermodynamics description of the ideal gas	PSO2	U	C	8
CO3	Understand the second law of thermodynamics and its applications	PSO2	U	C, P	12
CO4	Understand the basic ideas of entropy	PSO2	U	C	8
CO5	Understand the concepts of thermodynamic potentials and phase transitions	PSO2	U	C	12

Unit 1 – Zeroth Law and First Law of Thermodynamics

14 Hrs

Macroscopic point of view – Microscopic point of view – Macroscopic versus Microscopic points of view – Scope of Thermodynamics – Thermal equilibrium and Zeroth Law – Concept of temperature – Ideal-Gas temperature – Thermodynamic equilibrium – Equation of state – Hydrostatic systems – Intensive and extensive coordinates – Work – Quasi-static process – Work in changing the volume of a hydrostatic system – PV diagram – Hydrostatic work depends on the path – Calculation of work for quasi-static processes – Work and Heat – Adiabatic work – Internal energy function – Mathematical formulation of First Law – Concept of Heat – Differential form of the First Law – Heat capacity – Specific heat of water; the Calorie – Quasi-static flow of heat; Heat reservoir

[Sections 1.1 to 1.6, 1.10, 2.1 to 2.3, 2.10, 3.1 to 3.6 and 4.1 to 4.8, 4.10 of Heat and Thermodynamics by Zemansky and Dittman]

Unit 2 – Ideal Gas

8 Hrs

Equation of state of a gas – Internal energy of a real gas – Ideal gas – Experimental determination of heat capacities – Quasi-static adiabatic process – The microscopic point of view – Kinetic theory of the ideal gas

[Sections 5.1 to 5.5, 5.8 and 5.9 of Heat and Thermodynamics by Zemansky and Dittman]

Unit 3 – Second Law of Thermodynamics**12 Hrs**

Conversion of work into heat and vice versa – Heat engine; Kelvin-Planck statement of the Second Law – Refrigerator, Clausius' statement of the Second Law – Equivalence of Kelvin-Planck and Clausius statements – Reversibility and Irreversibility – Conditions for reversibility – Carnot engine and Carnot cycle – Carnot refrigerator – Carnot's Theorem and corollary – Thermodynamic temperature scale – Absolute zero and Carnot efficiency – Equality of ideal-gas and thermodynamic temperatures

[Sections 6.1, 6.6 to 6.9, 6.14, 7.1 and 7.3 to 7.7 of Heat and Thermodynamics by Zemansky and Dittman]

Unit 4 – Entropy**8 Hrs**

Reversible part of the Second Law – Entropy – Entropy of the ideal gas – TS diagram – Entropy and reversibility – Entropy and irreversibility – Irreversible part of the Second Law – Heat and entropy in irreversible processes – Principle of increase of entropy – Applications of the Entropy Principle – Entropy and disorder – Exact differentials

[Sections 8.1, 8.2, 8.4 to 8.9, 8.11 to 8.14 of Heat and Thermodynamics by Zemansky and Dittman]

Unit 5 – Thermodynamic Potentials and Phase Transitions**12 Hrs**

Characteristic functions – Enthalpy – Joule-Thomson expansion – Helmholtz and Gibbs functions – Condition for an exact differential – Maxwell's relations – TdS equations – PV diagram for a pure substance – PT diagram for a pure substance; Phase diagram – First-order phase transitions and Clausius-Clapeyron equation – Clausius-Clapeyron equation and phase diagrams

[Sections 10.1 to 10.6, 9.1, 9.2, 11.3 and 11.4 of Heat and Thermodynamics by Zemansky and Dittman]

Book of Study :

1. Heat and Thermodynamics, 7thEdn. – Mark W. Zemansky and Richard H. Dittman – McGraw-Hill

Reference Books :

1. Classical and Statistical Thermodynamics – Ashley H. Carter – Pearson, 2012
2. Basic Thermodynamics – Evelyn Guha – Narosa, 2002
3. Heat and Thermodynamics – D. S. Mathur – S. Chand Publishers, 2008
4. NPTEL video lectures available online

Mark distribution for setting Question paper.

Unit/ chapter	Title	Marks
1	Zeroth Law and First Law of Thermodynamics	20
2	Ideal Gas	12
3	Second Law of Thermodynamic	18
4	Entropy	12
5	Thermodynamic Potentials and Phase Transitions	17
<i>Total Marks *</i>		79

*Total marks include that for choice of questions in sections A, B and C in the question paper.

Semester 6 Core Course XI**PHY6B11: STATISTICAL PHYSICS, SOLID STATE PHYSICS, SPECTROSCOPY & PHOTONICS****54 Hours (Credit - 3)**

	Course Outcome	PSO	CL	KC	Class Sessions allotted
CO1	Understand the basic principles of statistical physics and its applications	PSO2	U	C	16
CO2	Understand the basic aspects of crystallography in solid state physics	PSO2	U	C	14
CO3	Understand the basic elements of spectroscopy	PSO2	U	C	4
CO4	Understand the basics ideas of microwave and infra red spectroscopy	PSO2	U	C	10
CO5	Understand the fundamental ideas of photonics	PSO2	U	C	10

Unit 1 Statistical Physics**16 Hrs**

Statistical Analysis – Classical versus quantum statistics – Distribution of molecular speeds – Maxwell-Boltzmann distribution – Quantum Statistics – Applications of Bose-Einstein statistics – Blackbody radiation – Applications of Fermi-Dirac statistics

[Sections 10.1 to 10.7 of Modern Physics by Kenneth Krane]

Unit 2 Solid State Physics**14 Hrs**

Lattice Points and Space Lattice-Basis and crystal structure, unit cells and lattice Parameters, Unit cells versus primitive cells, Crystal systems, Crystal symmetry, Bravais space lattices – Metallic crystal structures – simple cubic, body-centered cubic, face-centered cubic and hexagonal closed packed structure – Other crystal structures – Diamond, Zinc sulphide, Sodium chloride, Caesium chloride – Directions, Planes and Miller indices – Important features of Miller indices – Important planes and directions, distribution of atoms and separation between lattice planes in a cubic crystal – X-Ray diffraction – Bragg's law – Bragg's X-ray spectrometer – Powder crystal method

[Sections 4.1 to 4.7, 4.14 to 4.22 and 5.7 to 5.10 of Solid State Physics by S.O. Pillai]

Unit 3 Basic Elements of Spectroscopy**4 Hrs**

Quantization of Energy-Regions of Spectrum-Representation of Spectra-Basic Elements of Practical Spectroscopy-Signal to Noise Ratio-Resolving Power-Width and Intensity of Spectral Transitions

[Sections 1.2 to 1.7 of Fundamentals of Molecular Spectroscopy by Banwell and McCash]

Unit 4

Microwave Spectroscopy

5 Hrs

Rotation of molecules – Rotational spectra – Rigid diatomic molecules – Bond length of CO molecule – Intensities of spectral lines

[Sections 2.1 to 2.3.2 of Fundamentals of Molecular Spectroscopy by Banwell and McCash]

Infra Red Spectroscopy

5 Hrs

Energy of a diatomic molecule – Simple harmonic oscillator – Anharmonic oscillator – Morse curve – Selection rules and spectra – The spectrum of HCl – Hot bands – Diatomic vibrating rotator – Born-Oppenheimer approximation

[Sections 3.1 to 3.2 of Fundamentals of Molecular Spectroscopy by Banwell and McCash]

Unit 5 Photonics

10 Hrs

Interaction of light with matter – Absorption, spontaneous emission, stimulated emission, Einstein coefficients – Einstein relations – Light amplification – condition for stimulated emission to dominate spontaneous emission – condition for stimulated emission to dominate absorption – population inversion – metastable states – components of laser – lasing action – types of laser – Ruby laser, NdYAG laser, He-Ne laser, semiconductor laser – Applications – Raman effect – Classical explanation – quantum theory

[Sections 22.4 to 22.9, 22.14, 22.15, 22.19 and 22.20 of Textbook of optics by Brijlal, Subramaniam & Avadhanulu]

Books of Study:

1. Solid State Physics, 3rd Edn. – S. O. Pillai – New Age International Pvt. Ltd.
2. Fundamentals of Molecular Spectroscopy, 4th Edn. – Colin N. Banwell and Elaine M. McCash – McGraw-Hill
3. A Text Book of Optics, 25th Edn. – Subrahmanyam and Brijlal, S. Chand & Company Ltd., 2016

Reference Books :

1. Solid State Physics by M A Wahab
2. Molecular Structure & Spectroscopy by G Aruldas
3. Introduction to Molecular Spectroscopy by G M Barrow
4. Raman Spectroscopy by Long D A
5. NPTEL video lectures available online

Mark distribution for setting Question paper.

Unit/ chapter	Title	Marks
1	Statistical Physics	23
2	Solid State Physics	21
3	Basic Elements of Spectroscopy	6
4	Microwave Spectroscopy	7
5	Infra Red Spectroscopy	7
6	Photonics	15
<i>Total Marks *</i>		79

*Total marks include that for choice of questions in sections A, B and C in the question paper.

Semester 6 Core Course XII

PHY6B12: NUCLEAR PHYSICS AND PARTICLE PHYSICS

54 Hours (Credit - 3)

	Course Outcome	PSO	CL	KC	Class Sessions allotted
CO1	Understand the basic aspects of nuclear structure and fundamentals of radioactivity	PSO2	U	C	14
CO2	Describe the different types of nuclear reactions and their applications	PSO2	U	C, P	12
CO3	Understand the principle and working of particle detectors	PSO2	U	C, P	8
CO4	Describe the principle and working of particle accelerators	PSO2	U	C, P	8
CO5	Understand the basic principles of elementary particle physics	PSO2	U	C	12

Unit 1

1. Nuclear Structure and Radioactivity

14 Hrs

Nuclear Constituents – Nuclear sizes and shapes – Nuclear masses and binding energies – Liquid drop model – Shell model - Nuclear force – Radioactive decay – Conservation laws in radioactive decay – Alpha decay – Beta decay – Gamma decay – Natural radioactivity – Mossbauer effect
[Sections 12.1 to 12.11 of Modern Physics by Kenneth Krane; Sections 11.5, 11.6 of Beiser]

2. Nuclear Reactions and Applications

12 Hrs

Types of nuclear reactions – Radioisotope production in nuclear reactions – Low-energy reaction kinematics – Fission – Fission reactors – Fusion – Fusion processes in stars – Fusion reactors – Applications of nuclear physics – Neutron activation analysis, Medical radiation physics, Alpha decay applications, Synthetic elements
[Sections 13.1 to 13.6 of Modern Physics by Kenneth Krane]

Unit 2

3. Particle Detectors

8 Hrs

Particle Detectors – Wilson Cloud Chamber – Bubble Chamber – Ionization Chambers – Proportional Counter – Geiger-Muller Counter – Scintillation Counters and Semiconductor Counters – Spark Chamber – Cerenkov Counter – Neutron Counting – The Photographic Plate.
[Sections 17.1 to 17.11 of Atomic and Nuclear Physics – An Introduction by Littlefield and Thorley]

4. Particle Accelerators

8 Hrs

Particle Accelerators – Cockcroft-Walton Proton Accelerator – Van de Graaff Electrostatic Generator – Linear Accelerator – Lawrence Cyclotron – Synchrocyclotron – Electron Accelerating Machines : Betatron– Electron Synchrotron – Proton Synchrotron – Alternating-Gradient Synchrotron – Intersecting Beam Accelerators – The Growth and Future of Large Accelerating Machines

[Sections 18.1 to 18.12 of Atomic and Nuclear Physics – An Introduction by Littlefield and Thorley]

Unit 3

5. Elementary Particles

12 Hrs

The four basic forces – Particles and antiparticles – Families of particles – Conservation laws – Particle interactions and decays – Resonance particles – Energetics of particle decays – Energetics of particle reactions – The Quark Model – The Standard Model

[Sections 14.1 to 14.9 of Modern Physics by Kenneth Krane]

Books of study:

1. Modern Physics, 2ndEdn. – Kenneth S. Krane – John Wiley & sons
2. Atomic and Nuclear Physics – An Introduction, 3rdEdn. – T.A. Littlefield and N. Thorley – Springer
3. Concepts of Modern Physics, 7thEdn. – Arthur Beiser – Tata McGraw-Hill

Reference Books:

1. Modern Physics, 3rdEdn. – Raymond A. Serway, Clement J. Moses, Curt A. Moyer – Cengage
2. Quantum Physics of Atoms, Molecules, Solids, Nuclei & Particles By R.Eisberg & R. Resnick – John Wiley
3. Theory and Problems in Modern Physics by Gautreau & Savin – Schaum's Outlines Series – TMH
4. Modern Physics for Scientists and Engineers, 2ndEdn. – John R. Taylor, Chris D. Zafiratos, Michael A. Dubson – Prentice-Hall of India Pvt. Ltd
5. Modern Physics, 2ndEdn – Randy Harris – Pearson
6. A practical approach to Nuclear Physics, 1st Edition, K. Muraleedhara Varier- Narosa Publishing House
7. NPTEL video lectures available online

Mark distribution for setting Question paper.

Unit/ chapter	Title	Marks
1	Nuclear Structure and Radioactivity	20
2	Nuclear Reactions and Applications	18
3	Particle Detectors	12
4	Particle Accelerators	12
5	Elementary Particles	17
<i>Total Marks *</i>		79

*Total marks include that for choice of questions in sections A, B and C in the question paper.

Semester 6 | Core Course XIII
PHY6B13: RELATIVISTIC MECHANICS AND ASTROPHYSICS
54 Hours (Credit - 3)

	Course Outcome	PSO	CL	KC	Class Sessions allotted
CO1	Understand the fundamental ideas of special relativity	PSO2	U	C	18
CO2	Understand the basic concepts of general relativity and cosmology	PSO2	U	C	8
CO3	Understand the basic techniques used in astronomy	PSO2	U	C	10
CO4	Describe the evolution and death of stars	PSO2	U	C	12
CO5	Describe the structure and classification of galaxies	PSO2	U	C	12

Unit 1

1. Special Relativity

18 Hrs

The need for a new mode of thought – Michelson-Morley experiment – Postulates of Special Relativity – Galilean transformations – Lorentz transformations – Simultaneity – The order of events : Timelike and spacelike intervals – Lorentz length contraction – The orientation of a moving rod – Time dilation – Muon decay – Role of time dilation in an atomic clock - Relativistic transformation of velocity – Speed of light in a moving medium - Doppler effect – Doppler shift in sound – Relativistic Doppler effect – Doppler effect for an observer off the line of motion – Doppler navigation – Twin paradox – Relativistic Momentum and Energy – Momentum – Velocity dependence of the electron’s mass – Energy – Relativistic energy and momentum in an inelastic collision – The equivalence of mass and energy – Massless particles – Photoelectric effect – Radiation pressure of light – Photon picture of the Doppler effect – Does light travel at the velocity of light ? – The rest mass of the photon – Light from a pulsar

[Sections 11.1 to 11.5, 12.1 to 12.6, 13.1 to 13.4 of An Introduction to Mechanics (1stEdn.) by Daniel Kleppner and Robert J. Kolenkow]

Unit 2

2. General Relativity and Cosmology

8 Hrs

The principle of equivalence – General theory of relativity – Tests of general relativity – Stellar evolution – Nucleosynthesis – White dwarf stars – Neutron stars – Black holes – The expansion

of the universe – Cosmic microwave background radiation – Dark matter – Cosmology and general relativity – The big bang cosmology – Formation of nuclei and atoms – Echoes of the big bang – The future of the universe

[Sections 15.1 to 15.8 and 16.1 to 16.8 of Modern Physics (2ndEdn.) by Kenneth Krane]

Unit 3

3. Basic Tools of Astronomy

10 Hrs

Stellar distance – Relationship between stellar parallax and distance – Brightness and luminosity – Relationship between Luminosity, brightness and distance – Magnitudes – Apparent magnitude and brightness ratio – Relationship between apparent magnitude and absolute magnitude – Color and temperature of stars – Size and mass of stars – Relationship between flux, luminosity and radius – Star constituents – Stellar spectra – Stellar classification – Hertzsprung-Russell diagram – H-R diagram and stellar radius – H-R diagram and stellar luminosity – H-R diagram and stellar mass

[Sections 1.1 to 1.12 of Astrophysics is Easy : An Introduction for the Amateur Astronomer by Mike Inglis]

4. Stellar Evolution

12 Hrs

Birth of a Star – Pre-Main-Sequence evolution and the effect of mass – Galactic star clusters – Star formation triggers – The Sun – Internal structure of the sun – Proton-proton chain – Energy transport from the core to the surface – Binary stars – Masses of orbiting stars – Life times of main-sequence stars – Red giant stars - Helium burning – Helium flash – Star clusters, Red giants and the H-R diagram – Post-Main-Sequence star clusters : Globular clusters – Pulsating stars – Why do stars pulsate – Cepheid variables and the period-luminosity relationship – Temperature and mass of Cepheids – Death of stars – Asymptotic giant branch – The end of an AGB star's life – Planetary nebulae – White dwarf stars – Electron degeneracy – Chandrasekhar limit – White dwarf evolution – White dwarf origins – High mass stars and nuclear burning – Formation of heavier elements – Supernova remnants – Supernova types – Pulsars and neutron stars – Black holes

[3.1, 3.2, 3.4 to 3.15, 3.19 to 3.24 of Astrophysics is Easy : An Introduction for the Amateur Astronomer by Mike Inglis]

5. Galaxies

6 Hrs

Galaxy types – Galaxy structure – Stellar populations – Hubble classification of galaxies – Observing galaxies – spiral, barred spiral, elliptical, lenticular galaxies – Active galaxies and active galactic Nuclei (AGN) – Gravitational lensing – Hubble's law – Clusters of galaxies

[Sections 4.1 to 4.11 of Astrophysics is Easy : An Introduction for the Amateur Astronomer by Mike Inglis]

Books of Study:

1. An Introduction to Mechanics, 1st Edn. – Daniel Kleppner and Robert J. Kolenkow – McGraw-Hill
2. Modern Physics, 2nd Edn. – Kenneth S. Krane – John Wiley & sons
3. Astrophysics is Easy : An Introduction for the Amateur Astronomer – Mike Inglis – Springer

ReferenceBooks :

1. Introduction to Special Relativity – Robert Resnick – Wiley & Sons
2. Special Relativity – A P French – Viva Books India
3. An introduction to Astrophysics – BaidyanathBasu, PHI
4. Introduction to Cosmology -3rd Edn.–J.V.Narlikar, Cambridge University Press, 2002.
5. Principles of Cosmology and Gravitation – Michael Berry, Overseas Press, 2005.
6. Concepts of Modern Physics – Arthur Beiser, Tata McGraw-Hill
7. The Big and the Small (Vol II) by G. Venkataraman, Universities Press (India)
8. Chandrasekhar and His Limit by G. Venkataramn. Universities Press (India)
9. A Brief History of Time by Stephen Hawking, Bantam Books
10. NPTEL video lectures available online

Mark distribution for setting Question paper.

Unit/ chapter	Title	Marks
1	Special Relativity	27
2	General Relativity and Cosmology	12
3	Basic Tools of Astronomy	15
4	Stellar Evolution	17
5	Galaxies	8
<i>Total Marks *</i>		79

*Total marks include that for choice of questions in sections A, B and C in the question paper.

Semester 6 | Core Course XIV (Elective)
PHY6B14 (EL1): BIOMEDICAL PHYSICS
54 Hours (Credit - 3)

	Course Outcome	CL	KC	Class Sessions allotted
CO1	Understand the basic principles of biophysics	U	C	14
CO2	Understand the fundamentals of medical instrumentation	U	C	11
CO3	Understand the principles of ultrasound and x-ray imaging	U	C	10
CO4	Understand the basic principles of NMR	U	C	10
CO5	Describe the applications of lasers in medicine	U	C	9

Unit 1 Physical foundations of biophysics

14 Hrs

Free energy, Internal energy, Thermodynamics and Statistical mechanics, Reaction kinetics.
(Sections 4.1 to 4.4 from "Biophysics: An Introduction " by Rodney Cotterlie ,Wiley.)
 Transport Processes: Diffusion, Osmosis, Surface tension, Viscosity, thermal conduction.
(Sections 5.1 to 5.3 from "Biophysics: An Introduction " by Rodney Cotterlie ,Wiley.
 Oxidation and reduction, redox potential, examples of redox potential in biological systems.
Sections 4.5 and 9.3 from "Biophysics: An Introduction" by Rodney Cotterlie ,Wiley.
 Membrane Physics: Diffusion through cell membrane, factors affecting diffusion
 Membrane potentials: Resting potentials, action potentials, Hodgkin-Huxley model for membrane transport . Donnan equilibrium, Goldman equation.
(Sections 11.1, 11.2, 12.1, 12.2 from "Biophysics: An Introduction" by Rodney Cotterlie ,Wiley . Also refer: Principles of Biomedical engineering by Sundararajan V Madihally , Artech house.

Unit 2 Fundamentals of medical instrumentation

11 Hrs

Physiological systems of the body, sources of biomedical signals, basic medical instrumentation systems, performance, constraints and regulations, intelligent medical instrumentation systems. Origin of bioelectric signals, ECG, EEG, EMG. Recording electrodes and microelectrodes. Transducers and biosensors.

(Sections 1.1 to 1.8, 2.1 to 2.8 & 3.1 to 3.10 from " Handbook of Biomedical Instrumentation", R S Khandpur, Tata Mcgraw Hill)

Unit 3 Ultrasound and X ray medical imaging systems 10 Hrs

Ultrasonic Imaging-properties of ultrasound, modes of ultrasound transmission-pulsed, continuous, pulsed Doppler, ultrasound imaging, ultrasonic diagnosis, ultrasonic transducers.

(Sections 9.2, 9.3 from Leslie Cromwell, "Biomedical Instrumentation and measurement", Prentice hall of India, New Delhi)

X-rays- Instrumentation for diagnostic X-rays, visualization of X-rays-flouroscopy, X-ray filters, X-ray films, Image intensifiers, Special technique-grid, contrast media, Angiography.

(Sections 14.1 to 14.3 from Leslie Cromwell, "Biomedical Instrumentation and measurement", Prentice hall of India, New Delhi)

X-ray computed tomography – Computed tomography, basic principle, contrast scale, system components-scanning system, processing unit, viewing part, storage unit, Helical CT scanner.

(Sections 20.1, 20.2 from Handbook of Biomedical Instrumentation by R S Khandpur, Tata Mc GrawHill)

Unit 4 Nuclear medical imaging systems 10 Hrs

Nuclear Medical imaging systems-radio isotopes in medical imaging systems, physics of radioactivity, uptake monitoring equipment, radioisotope rectilinear scanner, gamma camera, Emission computed tomography, Positron emission tomography (PET Scanner)

(Sections 21.1, 21.2 from Handbook of Biomedical Instrumentation by R S Khandpur, Tata Mc GrawHill)

Principles of NMR, Image reconstruction techniques, Basic NMR components, Biological effects of NMR imaging, advantages of NMR imaging .

(Sections 22.1, 22.2, 22.3, 22.4, 22.5 from Handbook of Biomedical Instrumentation by R S Khandpur, Tata Mc GrawHill Publications)

(Reference- Medical Imaging Physics, William Hendee, John Wiley and Sons Publications)

Unit 5 Lasers in medicine 9 Hrs

Special properties of laser beam (coherence, collimation, monochromaticity), laser active medium, focal length of the laser lens, Laser-tissue interactions, Basic principles of Nd-YAG, CO₂, and Argon Lasers, An overview of their clinical applications with special reference to Gynecology, pulmonary, neurosurgery, dermatology, ophthalmology. Photodynamic therapy, Laser safety measures.

(Sections of Chapter 1, Chapter 2, Chapter 3, Chapter 5 from Lasers in Medicine - An Introductory Guide, Gregory Absten, Springer Science Publications)

Books of Study

1. Biophysics: An Introduction“ by Rodney Cotterlie ,Wiley
2. Handbook of Biomedical Instrumentation”, R S Khandpur, Tata Mcgraw Hill
3. “Biomedical Instrumentation and measurement”, Leslie Cromwell, Prentice hall of India
4. Lasers in Medicine - An Introductory Guide, Gregory Absten, Springer Science Publications

Books for Reference

1. Medical Physics by J R Cameron and J G Skofonick, Wiley Eastern)
2. The physics of medical imaging by S Webb, Hilger Publications
3. Techniques for radiation dosimetry by K Mahesh and D R Vij, Wiley Eastern Limited
4. Clinical nuclear medicine by Maisey, Britton, Chapman and Hall
5. Ultra sound in Medicine, by F Duck, IOP Publications
6. Medical Instrumentation Application and Design, by John G. Webster, John Wiley and sons, New York
7. Introduction to Biomedical equipment technology, John M. Brown, John Wiley and sons, New York
8. Medical Imaging Physics, W.R.Hendee & E.R.Ritenour, (3rd eds), Mosbey Inc.,

Mark distribution for setting Question paper.

Unit/ chapter	Title	Marks
1	Physical foundations of biophysics	20
2	Fundamentals of medical instrumentation	16
3	Fundamentals of medical instrumentation	15
4	Nuclear medical imaging systems	15
5	Lasers in medicine	13
<i>Total Marks *</i>		79

*Total marks include that for choice of questions in sections A, B and C in the question paper.

Semester 6 | Core Course XIV (Elective)

PHY6B14 (EL2): NANOSCIENCE AND TECHNOLOGY

54 Hours (Credit - 3)

	Course Outcome	CL	KC	Class Sessions allotted
CO1	Understand the elementary concepts of nanoscience	U	C	6
CO2	Understand the electrical transport mechanisms in nanostructures	U	C	10
CO3	Understand the applications of quantum mechanics in nanoscience	U	C	13
CO4	Understand the fabrication and characterization techniques of nanomaterials	U	C	19
CO5	Enumerate the different applications of nanotechnology	U	C	6

Unit 1: Introduction:

6 Hrs

Length scales in Physics- nanometer- Nanostructures: Zero, One Two and Three dimensional nanostructures (Chapter 3, Text 2)

Band Structure and Density of State at nanoscale: Energy Bands, Density of States at low dimensional structures. (Chapter 3, Text 1)

Unit 2: Electrical transport in nanostructure:

10 Hrs

Electrical conduction in metals, The free electron model. Conduction in insulators/ionic crystals - Electron transport in semiconductors - Various conduction mechanisms in 3D (bulk), 2D(thin film) and low dimensional systems: Thermionic emission, field enhanced thermionic emission (Schottky effect), Field assisted thermionic emission from traps (Poole-Frenkel effect), Arrhenius type activated conduction, Variable range, Hopping conduction, Polaron conduction. (Chapter 4, Text 1)

Unit 3: Introductory Quantum Mechanics for Nanoscience:

13 Hrs

Size effects in small systems, Quantum behaviors of nanometric world: Applications of Schrodinger equation - infinite potential well, potential step, potential box; trapped particle in 3D (nanodot), electron trapped in 2D plane (nanosheet), electrons moving in 1D (nanowire, nanorod, nanobelt), Excitons, Quantum confinement effect in nanomaterials (Chapter 5, Text 1)

Unit 4: Growth techniques of nanomaterials (Elementary ideas only): 9 Hrs

Top down vs bottom up techniques, Lithographic process, Non Lithographic techniques: Plasma arc discharge, sputtering. Evaporation: Thermal evaporation, Electron beam evaporation, Chemical Vapour Deposition (CVD), Pulsed Laser Deposition, Molecular Beam Epitaxy, Sol-Gel Technique, Electro-deposition., Ball-milling. (Chapter 6, Text 1: Sections 6.1, 6.2, 6.3, 6.4.1, 6.4.2, 6.4.2.1, 6.4.3, 6.4.3.1, 6.4.3.2, 6.4.4, 6.4.5, 6.4.6, 6.7, 6.4.8, 6.4.9)

Unit 5: Characterisation tools of nanomaterials: 10 Hrs

Scanning Probe Microscopy (SPM): Basic Principles of SPM techniques, details of STM, tunneling current, local barrier height, local density of states. Some applications of STM. (Section 7.1.1- 7.1.3.3, 7.1.3.5, Text 1), General concepts of AFM (Section 7.2.1 - 7.2.4, Text-1), Electron microscopy (7.3.1-7.3.6, Text -1).

Unit 6: Applications of nanotechnology: (Elementary ideas only) 6 Hrs

Buckminster fullerene, Carbon nanotube, nano diamond, BN Nanotube, Nanoelectronics - single electron transistor (no derivation), Molecular machine, Nanobiometrics (Chapter 8, Text 1). Applications of nanomaterials in energy, medicine and environment (Text 2)

Text books:

1. Introduction to Nanoscience & Nanotechnology by K. K. Chattopadhyaya and A. N. Banerjee, Publisher: PHI Learning and Private Limited
2. Nanotechnology, Rakesh Rathi, S Chand & Company, New Delhi

References:

1. Nanoparticle Technology Handbook- M. Hosokawa, K. Nogi, M. Naita, T. Yokoyama (Eds.), Elsevier 2007
2. Encyclopaedia of Materials Characterization, Surfaces, Interfaces, Thin Films, Eds. Brundle, Evans and Wilson, Butterworth- Heinmann, 1992
3. Springer Handbook of nanotechnology, Bharat Bhushan (Ed.), Springer-Verlag, Berlin, 2004
4. Nano Science and Technology, VS Muraleedharan and A Subramania, Ane Books Pvt. Ltd, New Delhi
5. A Handbook on Nanophysics, John D, Miller, Dominant Publishers and Distributors, Delhi-51
6. Introduction to Nanotechnology, Charles P Poole Jr. and Frank J Owens, Wiley Students Edition

7. Nano-and micro materials, K Ohno et. al, Springer International Edition 2009, New Delhi

Mark distribution for setting Question paper.

Unit/ chapter	Title	Marks
1	Introduction	9
2	Electrical transport in nanostructure	15
3	Introductory Quantum Mechanics for Nanoscience	19
4	Growth techniques of nanomaterials	12
5	Characterisation tools of nanomaterials	15
6	Applications of nanotechnology	9
<i>Total Marks *</i>		79

*Total marks include that for choice of questions in sections A, B and C in the question paper.

Semester 6 | Core Course XIV (Elective)
PHY6B14 (EL3): MATERIALS SCIENCE
54 Hours (Credit - 3)

	Course Outcome	CL	KC	Class Sessions allotted
CO1	Understand the basic ideas of bonding in materials	U	C	7
CO2	Describe crystalline and non crystalline materials	U	C	8
CO3	Understand the types of imperfections and diffusion mechanisms in solids	U	C	12
CO4	Describe the different properties of ceramics and polymers	U	C	15
CO5	Describe the different types of material analysis techniques	U	C	12

Unit 1

15 Hrs

Introduction

What is material science, Classification of materials-metals, ceramics, polymers, composites, Advanced materials, smart materials. (Section 1.1 to 1.6 of Callister's Material science and Engineering)

Bonds in materials

Atomic bonding in solids-bonding forces and energies, Primary bonding - Ionic bonding, Covalent bonding, metallic bonding, Secondary bonding- van der waals bonding, fluctuating induced dipole bonds, polar molecule induced dipole bonds, permanent dipole bonds example of anomalous volume expansion of water. (Section 2.5 to 2.8 of Callister's Material science and Engineering)

Crystals

Crystalline and Non Crystalline materials -Single crystals, polycrystals, Anisotropy, metallic crystal structures, atomic packing factors of FCC, BCC, Hexagonal close packed crystal structure, Density computations, Linear and planar densities, polymorphism and allotropy, non crystalline solids. (Section 3.8 to 3.11, 4.2 to 4.9 of Callister's Material science and Engineering)

Unit 2**12 Hrs****Imperfections in Solids**

Point defects, Vacancies and selfinterstitials, substitutional impurities, atomic point defects- Schottky defect, Frenkel defect, Dislocations-edge and screw dislocations, burgers vector, Interfacial defects-External surfaces, Grain boundaries, twin boundaries, stacking faults, Bulk and volume defects.(Section 5.2 to 5.8 of Callister's Material science and Engineering)

Diffusion in solids

Introduction, Diffusion mechanism, Vacancy diffusion, Interstitial diffusion, Steady state diffusion and Non-steady state diffusion, fick's laws, Factors that influence diffusion-temperature, diffusion species, example of aluminium for IC interconnects. diffusion in ionic and polymeric materials (section 6.1 to 6.8 of Callister's Material science and Engineering)

Unit 3**15 Hrs****Ceramics and its properties**

Glasses, Glass ceramics, properties, refractories -fire clay and silica refractories, Abrasives, cements, advanced ceramics-optical fibers, ceramic ball bearings, piezo electric ceramics, stress-strain behaviour of ceramics, flexural strength and elastic behaviour.(Section 12.1 to 12.8, 12.11 of Callister's Material science and Engineering)

Polymers and its properties

Different forms of Carbon-Diamond, Graphite, Fullerenes, Carbon nano tubes. (Qualitative aspects only)(Section 4.17 of Callister's Material science and Engineering)

Hydro carbon molecules, polymer molecules, homo polymers and copolymers, molecular weight calculation, linear polymers, branched polymers, cross linked polymers, network polymers, thermo setting and thermo plastic polymers, stress-strain behaviour and viscoelastic deformation of polymers. (Section 13.1 to 13.9, 14.2, 14.3, 14.4 of Callister's Material science and Engineering)

Unit 4**12 Hrs****Material Analysis Techniques**

Single crystal and powder diffraction techniques with diffractometer, Laue's technique and rotating crystal method, Microscopic techniques-Optical microscopy, electron microscopy, transmission electron microscopy, scanning electron microscopy, Scanning probe microscopy, construction and working of each device, Grain size determination technique. (Section 4.20, 5.12, 5.13 of Callister's Material science and Engineering)

Book for study

1. Material Science and Engineering by William D. Callister, Adapted by R. Balasubramanyam (IIT, Kanpur), Published by Wiley India Pvt Ltd (Reprint 2011)

Book for reference

1. Materials science and engineering- Vth Edn- V Raghavan(PHI)
2. Material science by S.L.Kakani & Amit Kakani, 2nd edition 2010, reprint 2011
3. Material Science & Engineering. R.K. Rajput (Jain Book Agency)
4. Material Science and Engineering, I. P . Singh, & Subhash Chander (Jain Book Agency)

Mark distribution for setting Question paper.

Unit/ chapter	Title	Marks
1	Unit 1	22
2	Unit 2	18
3	Unit 3	22
4	Unit 4	17
<i>Total Marks *</i>		79

*Total marks include that for choice of questions in sections A, B and C in the question paper.

B.Sc PROGRAMME IN PHYSICS (CORE)

PRACTICAL

All centres must arrange sufficient number of apparatus before the Practical Examination. All apparatus must be in proper condition before the Practical examination.

The external practical examination will be conducted at the end of 4th & 6th semesters. At the time of external examination, a student has to produce **certified fair record** with a minimum of **75%** of the experiments, listed in the syllabus. Valuation of the record must be done internally and externally. **A maximum of 1/2 mark can be awarded to an experiment which is neatly recorded.** Total mark for record in external valuation is 10. The principle or the logic and the relevant expressions of the experiment must be shown at the time of examination

Two test papers for practical internals could be conducted by including test papers in any two convenient cycles in the place of an experiment. A batch of students can be evaluated in each class. If there are a total of 4 cycles for a practical course, a test paper each can be included in the 3rd and 4th cycles. If there are a total of 3 cycles for a practical course, a test paper each can be included in the 2nd and 3rd cycles. A model examination can also conducted after completion of all cycles. Internal grade for test papers can be awarded based on the best two performances. Digital balance is allowed for mass measurements.

Number of questions in the question paper shall be 8 for Paper I & II; and 6 from Electronics & 2 from Python programs PAPER- III; out of these a minimum of 75% of the questions are to be set for the examination at a centre.

Semesters 1 to 4 | Core Course V
PHY4B05: PRACTICAL I
36 Hours in each semester (Credit - 5)

	Course Outcome	CL	KC	Class Sessions allotted
CO1	Apply and illustrate the concepts of properties of matter through experiments	Ap	P	36
CO2	Apply and illustrate the concepts of electricity and magnetism through experiments	Ap	P	36
CO3	Apply and illustrate the concepts of optics through experiments	Ap	P	36
CO4	Apply and illustrate the principles of electronics through experiments	Ap	P	36

(Any 20 experiments)

1. Young's modulus-non uniform bending-using pin and microscope-(load-extension graph)
2. Young's modulus-Uniform bending-using optic lever
3. Moment of inertia-Flywheel (Calculate percentage error and standard deviation)
4. Moment of Inertia-Torsion Pendulum
5. Rigidity modulus-static torsion
6. Compound pendulum-acceleration due to gravity, Radius of gyration
7. Katers pendulum- Acceleration due to gravity
8. Liquid lens-Refractive index of liquid and glass -a) determine R using a)water& b) Buoy's method
9. Spectrometer-solid prism-Refractive index of the material of the prism , measuring angle of minimum deviation
10. Spectrometer-solid prism- Dispersive power
11. a. Searle's vibration magnetometer- ratio of moments b. Searle's and box type vibration magnetometers-m & Bh.
12. Melde's string arrangement-Frequency, relative density of liquid and solid (both modes)
13. Mirror Galvanometer-figure of merit
14. Potentiometer-calibration of ammeter
15. Ballistic Galvanometer- BG constant using HMS-then find Bh.
16. Ballistic galvanometer-Comparison of capacitance- Desauty's method

17. Spectrometer- i-d curve
18. Verification of Thevenin's theorem and maximum power transfer theorem
19. Lissajous figures – Measurement of frequency and phase shift of sinusoidal signals using CRO
20. Cantilever –scale and telescope /pin and microscope
21. Single slit diffraction using LASER
22. Determination of dielectric constant of liquid/thin sheet
23. Thermo emf measurement using digital multimeters - study of Seebeck effect
24. Thermal conductivity of a good conductor by Searle's method.

Books of Study:

1. Electronics lab manual- K A Navas (vol 1 &2)
2. B.Sc Practical Physics- C L Arora
3. Practical Physics- S L Gupta & V Kumar

Reference Books:

1. Advanced Practical Physics for students – B L. Worksnop and H T Flint

Semesters 5-6 | Core Course XV
PHY6B15: PRACTICAL II
72 Hours in each semester (Credit - 5)

	Course Outcome	CL	KC	Class Sessions allotted
CO1	Apply and illustrate the concepts of properties of matter through experiments	Ap	P	36
CO2	Apply and illustrate the concepts of electricity and magnetism through experiments	Ap	P	36
CO3	Apply and illustrate the concepts of optics and spectroscopy through experiments	Ap	P	36
CO4	Apply and illustrate the principles of heat through experiments	Ap	P	36

(Any 20 experiments)

1. ϵ/m measurement -Thomson's apparatus
2. Spectrometer-Cauchy's constants
3. Spectrometer-Diffraction Grating-Normal incidence
4. Spectrometer- Diffraction Grating-minimum deviation
5. Spectrometer $i_1 - i_2$ curve
6. Laser-wavelength using transmission grating
7. Spectrometer-Quartz prism-Refractive indices of quartz for the ordinary and extra ordinary rays
8. Newton's rings-wavelength of sodium light
9. Air wedge-angle of the wedge, radius of a thin wire
10. Lee's Disc -thermal conductivity of a bad conductor
11. Potentiometer-calibration low range and high range voltmeters
12. Potentiometer- Reduction factor of TG
13. Variation of field with distance-Circular coil-moment of magnet & Bh
14. Resolving power of grating
15. Carey Foster's bridge-Temperature coefficient of Resistance
16. Conversion of Galvanometer to voltmeter and calibrating using Potentiometer. (Plot using software)
17. Conversion of Galvanometer to ammeter and calibrating using Potentiometer.

18. BG Absolute Capacity
19. BG-High resistance by leakage method
20. Dispersive power of grating
21. Planck's constant using LED's (Minimum 4 nos.)
22. Polarimeter-Specific rotation of sugar solution.
23. Numerical aperture of an optical fibre by semiconductor laser
24. Frequency of AC using Sonometer

Books of Study:

1. Electronics lab manual- K A Navas (vol 1 &2)
2. B.Sc Practical Physics- C L Arora
3. Practical Physics- S L Gupta & V Kumar

Reference Books:

1. Advanced Practical Physics for students – B L Worksnop and H T Flint
2. A practical approach to Nuclear Physics, 1st Edition, K. Muraleedhara Varier- Narosa Publishing House.

Semester 5-6 | Core Course XVI**PHY6B16: PRACTICAL III****72 Hours in each semester (Credit - 5)**

	Course Outcome	CL	KC	Class Sessions allotted
CO1	Apply and illustrate the principles of semiconductor diode and transistor through experiments	Ap	P	36
CO2	Apply and illustrate the principles of transistor amplifier and oscillator through experiments	Ap	P	36
CO3	Apply and illustrate the principles of digital electronics through experiments	Ap	P	36
CO4	Analyze and apply computational techniques in Python programming	Ap	P	36

Unit: 1 (Any 15 experiments)

1. Construction of full wave a) Centre tapped and b) Bridge rectifiers
2. Characteristics of Zener diode and construction of Voltage regulator.
3. Transistor input, output & transfer characteristics in Common Base Configuration and calculation of current gain.
4. Transistor input, output & transfer characteristics in Common emitter Configuration and calculation of current gain
5. CE Transistor Amplifier-Frequency response.(Design the circuit for a given collector current I_c)
6. Negative feedback amplifier
7. Half adder using NAND gates
8. Full adder using NAND gates-construction & verification
9. LC Oscillator (Hartley or Colpitt's)
10. Phase shift oscillator
11. Operational Amplifier –inverting, non inverting, Voltage follower
12. LCR circuits-Resonance using CRO
13. Construction of basic gates using diodes (AND, OR) & transistors (NOT), verification by measuring voltages
14. Voltage multiplier (doubler, Tripler) (Connections to be realized through soldering. The desoldering has to be carried out at the end of the experiment.)
15. Multivibrator using transistors.

16. Flip-Flop circuits –RS and JK using IC's
17. Verification of De-Morgan's Theorem using basic gates.
18. Photo diode V-I characteristics. Determine quantum efficiency and responsivity of the PD
19. Study the characteristics of LED (3 colours) and LDR.
20. Wave shaping R-C circuits -integrator and differentiator
21. OPAMP- adder, subtractor

Unit: II Numerical Methods Using Python: Minimum 5 programs to be done.

21. Solution of equations by bisection and Newton-Raphson methods
22. Least square fitting – straight line fitting.
23. Numerical differentiation using difference table.
24. Numerical Integration – Trapezoidal and Simpson's 1/3 rd rule.
25. Taylor series - Sin θ , Cos θ
26. Solution of 1st order differential equation Runge-Kutta method
27. Simulation of freely falling body. Tabulation of position, velocity and acceleration, as function of time.
28. Simulation of projectile – Tabulation of position, velocity and acceleration as a function of time – Plot trajectory in graph paper from tabulated values.

Books of Study:

1. Electronics lab manual- K A Navas (vol 1 &2)
2. B.Sc Practical Physics- C L Arora
3. Practical Physics- S L Gupta & V Kumar
4. Computational Physics, V.K.Mittal, R.C.Verma & S.C.Gupta-Published by Ane Books
5. Introductory methods of numerical analysis, S.S.Shastry , (Prentice Hall of India,1983)
- 6.Introduction to Python for Engineers and Scientists by Dr.Sandeep Nagar, Apress publications.
- 7.Python for Education by Dr. B P Ajithkumar, IUAC, New Delhi; e-book freely downloadable from www.expeyes.in/documents/mapy.pdf

Reference Books:

1. Advanced Practical Physics for students – B L. Worksnop and H T Flint

Semester 5-6 | Core Course XVII
Course: PHY6B17(P) – PROJECT
36 Hours in each semester (Credits: 2)

	Course Outcome	CL	KC	Class Sessions allotted
CO1	Understand research methodology	U	P	18
CO2	Understand and formulate a research project	C	P	18
CO3	Design and implement a research project	C	P	18
CO4	Identify and enumerate the scope and limitations of a research project	C	P	18

Semester 5-6 | Core Course XVII
PHY6B17(R): RESEARCH METHODOLOGY (In lieu of Project)
36 Hours in each semester (Credits: 2)

	Course Outcome	CL	KC	Class Sessions allotted
CO1	Understand research methodology	U	C, P	18
CO2	Understand the concept of measurement in research	C	C, P	16
CO3	Understand the significance and limitations of experimentation in research	C	C, P	16
CO4	Understand and formulate a research project, ethics and responsibility of scientific research	C	C, P	22

Unit 1 Methodology of Science**18 Hrs Science**

as facts, science as generalization, Some distinctions when describing science, Science as a social activity, scientific revolutions and paradigms, Science and pseudo-science, Science and democratic development, The limitations of science-presuppositions, fundamental questions on reality: Rationality, Description, Causality - Prediction and Explanation in science - Mathematics and science, Hypothesis, Theories and laws, Verification, Falsification, Acceptance - Peer Review in Science - Scientific method. (Sections 2.2.1 to 2.2.5, 2.3.1, 2.4.1, 2.5.1 to 2.5.4, 2.6.1 to 2.6.4, 2.8.1 to 2.8.4, 3.1 to 3.3, 4.1 to 4.4, 7.1 *The Aims, Practices and Ethics of Science*, Peter Pruzan, Springer International Publishing Limited)

Unit 2 Measurement**16 Hrs**

Processes, Instruments and Operationalization, (Variables and Indicators), Criteria in Measurement, Validity, Reliability, Reproducibility/Replicability, Measurement Error, Potential Sources of Measurement Error, Random and Systematic Errors.

(Sections 5.2.1 to 5.2.2, , 5.2.3, *The Aims, Practices and Ethics of Science*, Peter Pruzan, Springer International Publishing Limited)

Unit 3 Experimentation**16 Hrs**

The Roles and Limitations of Experimentation, Natural Experiments, Manipulative Experiments, Comparative Experiments, Experimentation and Research, Conducting Experiments, Validity and Reliability in Experimentation, Reliability, Epistemological Strategies, Design of Experiments.

[Sections 6.1.1 to 6.1.2, , 6.1.3, 6.2, 6.3, 6.4 *The Aims, Practices and Ethics of Science*, Peter Pruzan, Springer International Publishing Limited]

Unit 4 Scientific Method and Design of Research**22 Hrs****Design**

The Scientific Method, Research Design, Components, Research Design and Your Proposal, Purpose of Your Proposal, Proposal Structure, Conceptual Framework (or Literature Review), Research Questions/Hypotheses, Methods/Methodology, Validity, Concluding sections to your proposal,

[Sections 7.1 to 7.2, , 7.2.1, 7.2.2, *The Aims, Practices and Ethics of Science*, Peter Pruzan, Springer International Publishing Limited]

Research

Basic, Applied and Evaluation Research, Multidisciplinary and Interdisciplinary Research, The Value of Having Research Skills, Formulating a Research Problem, Research in Relation to Teaching and Publishing. Ethics and Responsibility in Scientific Research, Ethics, Western and Eastern Perspectives on the Source of Ethics, Unethics, Guidelines for Ethical Practices in Research, Plagiarism, Integrity of data, Use and misuse of data, Ownership of and access to data, Obligation to report, Conflict of Interest, From Unethics to Ethics in Research, The Responsibility of Scientists and of Science as an Institution

[Sections 9.1, 9.2, , 9.3, 9.4, 9.5, 10.1, 10.2, 10.3, 10.4 The Aims, Practices and Ethics of Science, Peter Pruzan, Springer International Publishing Limited]

Book for study

1.The Aims, Practices and Ethics of Science, Peter Pruzan, Springer International Publishing Limited

Reference Books

1. Research Methodology – Methods and Techniques (3rd ed.) by C R Kothari & Gaurav Garg, New Age International Publishers, 2014
2. Research Methodology and Scientific Writing by C George Thomas, Ane Books Pvt. Ltd., 2016

B.Sc. PHYSICS
OPEN COURSES SYLLABUS

Semester 5 Open Course I
PHY5D01(1): NON CONVENTIONAL ENERGY SOURCES
54 Hours (Credit – 3)

	Course Outcome	CL	KC	Class Sessions allotted
CO1	Understand the importance of non conventional energy sources	U	C	4
CO2	Understand basic aspects of solar energy	U	C	12
CO3	Understand basic principles of wind energy conversion	U	C	10
CO4	Understand the basic ideas of geothermal and biomass energy and recognize their merits and demerits	U	C	16
CO4	Understand the basic ideas of oceans and chemical energy resources and recognize their merits and demerits	U	C	12

Unit 1

4 Hrs

Energy Resources-Non Conventional Energy Sources-Renewable and Non-Renewable energy sources.

(Section 1.3, 1.4 and 1.5 from Non- Conventional Energy Sources and Utilisation by R.K.Rajput, S.Chand Publishers, 1st Edition.)

Unit 2

Solar energy

12 Hrs

Solar Energy Terms and Definitions- Solar Constant, Solar radiation measurements, Solar energy collector, Physical principle of the conversion of solar radiation in to heat, solar air heaters and drying, solar cookers, solar distillation, solar furnaces, solar greenhouses, solar power plants, solar photovoltaic cells(no need of mathematical equations)

(Section 2.2.1 and 2.2.2, 2.3, 3.1.2, 3.1.3-3.1.5, 3.2, 3.3.1-3.3.3, 3.4.1-3.4.10, 4.16, 4.17, 4.18, 4.19, 4.20, 4.21.4, 4.21.8, 4.21.9, 4.21.10, 4.21.4 from Non- Conventional Energy Sources and Utilisation by R.K.Rajput, S.Chand Publishers, 1st Edition.)

Unit 3 Wind energy

10 Hrs

Introduction, Utilisation aspects of wind energy, Advantages and Disadvantages of wind energy, Environmental impact of wind energy, Sources/Origins of wind, Principle of wind energy

conversion and wind power, Basic components of wind energy conversion system(WECS), Advantages and Disadvantages of WECS, Wind-Electric Generating Power Plant, Wind Energy Economics, Problems in operating large wind power generators.

(Section 5.1-5.6, 5.8, 5.10, 5.11, 5.20, 5.25, 5.26 from Non- Conventional Energy Sources and Utilisation by R.K.Rajput, S.Chand Publishers, 1st Edition.)

Unit 4

16 Hrs

Geothermal energy

Introduction to Geothermal energy, Important aspects of Geothermal Energy, Structure of Earth's interior, Geothermal system-Hot Spring structure, Geothermal Resources (Hydrothermal, Geopressured, Petro-thermal system, Magma Resources), Advantages and disadvantages of geothermal energy over other energy forms, application of geothermal energy.

(Section 7.1, 7.2, 7.3, 7.5, 7.8.1, 7.8.2, 7.8.3, 7.8.4, 7.9, 7.10 from Non- Conventional Energy Sources and Utilisation by R.K.Rajput, S.Chand Publishers, 1st Edition.)

Energy from biomass:

Introduction to biomass, Biomass resource, Biomass Conversion process (Densification, Combustion and incineration, Thermo Chemical conversion, Biochemical conversion), Biogas: Biogas Applications, Biogas Plants (Raw materials used, Main Components of a Biogas Plant)

(Section 6.1, 6.2, 6.5.1, 6.5.2, 6.5.3, 6.5.4, 6.6.1, 6.6.2, 6.7.1, 6.7.2, 6.7.3 from Non- Conventional Energy Sources and Utilisation by R.K.Rajput, S.Chand Publishers, 1st Edition.)

Unit 5. Energy from Oceans and Thermal and Chemical effects

12 Hrs

Ocean Energy, Ocean Energy Sources, Tidal energy, Components of a Tidal Power Plant, Economic aspects of tidal energy conversion, Wave energy, Advantages and disadvantages, Factors affecting Wave energy, Ocean Thermal Energy Conversion (OTEC), Working principle of OTEC, Efficiency of OTEC, Types of OTEC Plants (Closed system, Thermoelectric OTEC system), Advantages and Disadvantages and Applications of OTEC.

Thermo electric effects, Fuel Cells, Hydrogen energy, Nuclear Reactors, Advantages and Disadvantages of Nuclear power plants (Basic Principles/concepts only)

(Section 8.1, 8.2, 8.3.1, 8.3.8, 8.3.14, 8.4.1, 8.4.2, 8.4.3, 8.5.1, 8.5.3, 8.5.4, 8.5.5.1, 8.5.5.5, 8.5.6, 9.2, 9.7.1, 9.7.2, 9.7.3, 10.1, 10.2, 10.3, 11.2.1, 11.5 from Non- Conventional Energy Sources and Utilisation by R.K.Rajput, S.Chand Publishers, 1st Edition.)

Books of study:

1. Non- Conventional Energy Sources and Utilisation by R.K.Rajput, S.Chand Publishers

References

1. Non- Conventional Energy Resources by G. D. Rai, Khanna Publishers, 2008.
2. Solar Energy Fundamentals and application by H.P. Garg and J. Prakash, Tata McGraw- Hill Publishing company Ltd, 1997.
3. Solar Energy by S. P. Sukhatme, Tata McGraw- Hill Publishing company Ltd,1997.
4. Solar Energy Utilization by G.D. Rai, Khanna Publishers, 1995.

Mark distribution for setting Question paper.

Unit/ chapter	Title	Marks
1	Non Conventional energy	06
2	Solar energy	18
3	Wind energy	15
4	Geothermal energy and energy from biomass	22
5	Energy from Oceans and Chemical energy resources	18
<i>Total Marks *</i>		79

*Total marks include that for choice of questions in sections A, B and C in the question paper.

Semester 5 Open Course I**PHY5D01(2): AMATEUR ASTRONOMY AND ASTROPHYSICS****54 Hours (Credit – 3)**

	Course Outcome	CL	KC	Class Sessions allotted
CO1	Describe the history and nature of astronomy as a science	U	C	18
CO2	Understand the motion of earth in space and the cause of seasons	U	C	12
CO3	Understand the basic elements of solar system	U	C	12
CO4	Understand the elementary concepts of solar system	U	C	12

Unit 1. Introduction and Development of Astronomy**18 Hrs**

Introduction & Brief history of Astronomy Astronomy & Astrology-Fascinations of Astronomy- Two important Branches of Astronomy-Amateur observational Astronomy- Different types of Amateur Observing- Ancient Astronomy & modern astronomy-Indian & western

Unit 2. Earth**12 Hrs**

Earth The zones of earth-longitude and latitude-shape of earth. Keplers laws- perihelion- Aphelion perigee and apogee, year-month-Day. Seasons-causes of seasons

Unit 3. Sun**12 Hrs**

Solar system sun-structure-photosphere-chromosphere-solar constant-sun temperature-sun spots-solar eclipse corona- (planets-surface conditions and atmosphere, size, period & distance) mercury-venus-earthmars-jupiter-saturn-uranus-neptune-comets-asteroidsmeteors

Unit 4. Stars**12 Hrs**

The stars Unit of distance-Astronomical units--parsec-light year-Magnitudes of stars- apparent magnitude absolute magnitude-Three categories of stars-Main sequence stars Dwarfs-Giants-star formation life cycle of stars-Chandrasekher limit- Novae-Binary stars- neutron star-black holes. Expanding universe-Big bang theory

Books of study:

1. A Text book on Astronomy- K K Dey, Book Synticate Pvt. Ltd.
2. Introduction to Astrophysics - Baidanath Basu, PHI, India
3. Elements of Cosmology- Jayant Narlikar, University Press,

Reference books.

1. Astrophysics of Solar System - K D Abhyankar, University press
2. Chandrasekhar and his limit- G Venkataraman, University Press
3. The Big & The small (Volume II) - G Venkataraman, University Press
4. Joy of Sky Watching- Biman Basu, National Book Trust
5. Astronomy- Principles & practices, A E Roy & D Clarke, Institute of Physics

Mark distribution for setting Question paper.

Unit/ chapter	Title	Marks
1	Introduction	26
2	Earth	18
3	Sun	18
4	Stars	17
<i>Total Marks *</i>		79

*Total marks include that for choice of questions in sections A, B and C in the question paper.

Semester 5 ♦ Open Course I
PHY5D01(3): ELEMENTARY MEDICAL PHYSICS
54 Hours (Credit – 3)

	Course Outcome	CL	KC	Class Sessions allotted
CO1	Understand the basic aspects of physics of nuclear medicine	U	C	18
CO2	Recognize different bioelectric signals and their instrumentation	U	C	18
CO3	Understand the basic elements of X-ray imaging	U	C	9
CO4	Understand the basic elements of ultrasound imaging and its advantages and disadvantages	U	C	9

Unit 1 Nuclear medicine physics

18 Hour

Nuclear physics -Introduction to Radioactivity-Artificial and natural-Physical features of radiation, conventional sources of radiation, Interaction of different types of radiation with matter-Ionizing & Non ionizing Radiations-excitation, ionization, and radioactive losses- Neutron interactions, Rayleigh scattering-Compton scattering-photoelectric effect-Pair production (Qualitative Study only), Radiation quantity and quality-Radiation exposure, Units of radiation dose, Measurement of radiation dose, safety, risk, and radiation protection-Radiopharmaceuticals -Radioactive agents for clinical studies- Biological effects & Genetic effect of radiation.

Unit 2 Medical instrumentation

18 Hrs

Measurements of Non electrical parameters: Respiration-heart rate-temperature-blood pressure - Electrocardiography (ECG): Function of the heart-Electrical behaviour of cardiac cells-Normal and Abnormal cardiac rhythms-Arrhythmias Electro-encephalography(EEG): Function of the brain-Bioelectric potential from the brain-Clinical EEG-Sleep patterns-The abnormal EEG, Electromyography(EMG): Muscular servomechanism-Potentials generated during muscle actions

Unit 3 Medical imaging techniques

18 Hrs

X-ray imaging-properties of X -rays- Production of X-rays--Planar X-ray imaging instrumentation-X-ray fluoroscopy. Ultrasound imaging- generation and detection of ultrasound- Properties -reflection -transmission- attenuation -Ultrasound instrumentation- Principles of A mode, B-mode-M-mode Scanning, Hazards and safety of ultrasound.

Books of study:

1. W.R.Hendee & E.R.Ritenour, Medical Imaging Physics (4th edn) Wiley New York,
2. John G. Webster, "Medical Instrumentation Application and Design", John Wiley and sons, New York, 1998.,
3. Khandpur R.S, "Handbook of Biomedical Instrumentation", Tata McGraw- Hill, New Delhi, 1997.

Reference books:

1. Medical Physics by Glasser O, Vol 1,2,3 Year Book Publisher Inc Chicago
2. Leslie Cromwell, "Biomedical Instrumentation and measurement", Prentice hall of India, New Delhi, 1999.
3. John G. Webster, "Medical Instrumentation Application and Design", John Wiley and sons, New York, 1998.
4. Khandpur R.S, "Handbook of Biomedical Instrumentation", Tata McGraw-Hill, New Delhi, 1997.
5. Joseph J.carr and John M. Brown, "introduction to Biomedical equipment technology", John Wiley and sons, New York, 1997..
6. W.R.Hendee & E.R.Ritenour, Medical Imaging Physics (3'd eds), Mosbey Year-Book, Inc., 1992.
7. Hendee & E.R.Ritenour, Medical Physics.

Mark distribution for setting Question paper.

Unit/ chapter	Title	Marks
1	Nuclear medicine physics	27
2	Medical instrumentation	26
3	Medical imaging techniques	26
<i>Total Marks *</i>		79

*Total marks include that for choice of questions in sections A, B and C in the question paper.

B.Sc. PHYSICS
COMPLEMENTARY COURSES SYLLABUS
(For B. Sc Programme in Mathematics, Chemistry etc)

Semester 1 | Complementary course-I
PHY1C01: Properties of matter & Thermodynamics
36 Hours (Credit - 2)

	Course Outcome	CL	KC	Class Sessions allotted
CO1	Understand the basic principles of elasticity	U	C	9
CO2	Understand the concepts of surface tension	U	C	5
CO3	Understand the aspects of viscosity	U	C	4
CO4	Understand the basic principles of thermodynamics	U	C	18

Unit 1 Elasticity.

9 Hrs

Elastic moduli. (Elementary ideas)- Work done per unit volume - Poisson's ratio and theoretical limits - relation between various elastic constants(Derivation not required)- Twisting couple on a cylinder(Derivation not required)- Torsion pendulum-Determination of rigidity modulus of a wire- Bending of beams-bending moment- I-forra girders- Cantilever loaded at the free end – Loaded uniformly (Derivation required)

Unit 2 Surface Tension & Viscosity.

9 Hrs

Surface tension (Elementary ideas)-Excess pressure inside a liquid drop and bubble (Effect of electrostatic pressure on a bubble-change in radius)-Work done in blowing the bubble (problem based on the formation of bigger drop by a number of smaller drops)

Viscosity-Coefficient of viscosity-Derivation of poiseuille's equation, stokes equation- Determination of viscosity by Poiseuille's method and stokes method-Brownian motion – Viscosity of gases

Unit 3 Thermodynamics

18 Hrs

Thermodynamic processes –Indicator diagram (P-V diagram, P-T diagram, T-V diagram, T-S diagram)- Work done in Quasi static process-Work done in Isothermal, Adiabatic, Isochoric, Isobaric processes-First law of thermodynamics-Application to heat capacities- Second law of thermodynamics- Carnot's engine - Derivation of efficiency using Carnot's cycle-Carnot's theorem and its proof- Carnot's refrigerator(coefficient of performance)-

Entropy- Change of entropy in a carnot's cycle, reversible cycle , irreversible cycle principle of increase of entropy- Entropy and available energy- entropy and disorder - Clausius-Clapyron equation(Derivation not required)-Effect of pressure on melting point and boiling point.

Text for study

1. Properties of matter-D. S. Mathur
2. Properties of matter-JC Upadhaya
3. Heat and Thermo dynamics- Brijlal and Subrahmanyam

Books for reference

- 1.. Heat and Thermo dynamics- D S Mathur
2. Heat and Thermodynamics - Zemansky
3. Physics- Resnick and Halliday
4. Thermodynamics- Brijlal and Subrahmanyam

Mark distribution for setting Question paper.

Unit/ chapter	Title	Marks
1	Elasticity	20
2	Surface Tension & Viscosity	20
3	Thermodynamics	39
<i>Total Marks *</i>		79

*Total marks include that for choice of questions in sections A, B and C in the question paper.

Semester 2 | Complementary Course II
PHY2C02: Optics, Laser & Electronics
36 Hours (Credit - 2)

	Course Outcome	CL	KC	Class Sessions allotted
CO1	Understand the basic concepts of interference and diffraction	U	C	16
CO2	Understand the concepts of polarization	U	C	6
CO3	Understand the fundamentals of electronics	U	C	10
CO4	Understand the important principles of laser physics	U	C	4

Unit 1 Interference

8 Hrs

Superposition of two sinusoidal waves (resultant amplitude and intensity), constructive and destructive interference- Fresnel's two mirror arrangement - Interference by a plane film- colours of thin films- Newton's rings (Reflected system)-Determination of wavelength

Unit 2 Diffraction

8 Hrs

Fresnel and Fraunhofer class of diffraction Fraunhofer single slit diffraction pattern- Intensity distribution (qualitative ideas only)- plane diffraction Grating-resolving power and dispersive power. Experiment with grating

Unit 3 Polarisation

6 Hrs

Elementary idea- Brewster' law- Double refraction- positive and negative crystals- Quarter and half wave plate- production of plane, elliptically and circularly polarized light- optical activity

Unit 4 Electronics

10 Hrs

Half wave, Full wave and bridge rectifier circuits- Efficiency & ripple factor- Filter circuits (capacitor filter and π filters) – Zener diode characteristics- Voltage stabilization Transistors- CB, CE, CC Configurations- CE (only) characteristics- Current amplification factors - relation connecting α , β and γ – CE Amplifier- frequency response- band width Basic principle of feedback, concept of an oscillator circuit, Logic gates- Universal gates- De- Morgan's theorem – Exclusive OR gate

Unit 5 Laser physics

4 Hrs

Induced absorption- spontaneous emission and stimulated emission- population inversion Principle of Laser-Types of laser- Ruby laser, Helium Neon laser

Text for study:

1. Optics - Brijlal & Subramanian
2. Principles of Electronics-VK Mehta

Books for reference

1. Optics- Ajay Ghatak
2. Optics – Brijlal &Subramaniam
3. Laser fundamentals – Sølfrast
4. Lasers – theory & applications- Thyagarajan & Ghatak

Mark distribution for setting Question paper.

Unit/ chapter	Title	Marks
1	Interference	18
2	Diffraction	18
3	Polarisation	13
4	Electronics	21
5	Laser Physics	9
<i>Total Marks *</i>		79

*Total marks include that for choice of questions in sections A, B and C in the question paper.

Semester 3 | Complementary Course III
PHY3C03: Mechanics, Relativity, Waves and Oscillations
54 Hours (Credit - 3)

	Course Outcome	CL	KC	Class Sessions allotted
CO1	Understand the basic ideas of frames of reference and the principles of conservation of energy and momentum	U	C	22
CO2	Understand the concepts of relativity	U	C	12
CO3	Understand the basic ideas of oscillations and waves	U	C	10
CO4	Understand the basic ideas of modern physics	U	C	10

Unit 1 Frames of reference.

8 Hrs

Inertial frame of reference-Galilean transformation equations and Invariance- Non inertial frames- Centrifugal force and Coriolis force

Unit 2. Conservation of Energy and Momentum

14 Hrs

Conservation of energy of a particle –Energy function- Potential energy curve- Conservative and Non conservative forces- Conservation of Linear momentum-Center of mass frame of reference- Rockets- motion under central force- Conservation of angular momentum (Illustrate suitable example)

Unit 3 Relativity

12 Hrs

Postulates of special theory-Michelson Morley experiment-Lorentz transformation equations- Length contraction-Time dilation- Twin paradox- variation of mass with velocity-Mass energy relation- momentum energy relation

Unit 4 Oscillation and Waves

10 Hrs

Simple harmonic motion (Elementary idea) - equation –examples like oscillation of simple pendulum, loaded spring-An harmonic oscillator-Damped harmonic oscillator. Wave motion- Equation for plane progressive wave-Energy density- Pressure variations of plane waves.

Unit 5 Introduction to Modern Physics

10 Hrs

Electromagnetic waves -Black body radiation, UV catastrophe(Qualitative ideas), Photoelectric effect, wave-particle duality, de Broglie hypothesis, Uncertainty Principle, Energy and momentum

operators, Schrödinger's time dependent and time independent equations(elementary ideas only), Eigen values and eigen functions .

Text for Study:

1. Mechanics:J C Upadhyaya
2. Modern Physics-Arthur Beiser

Books for reference-

1. Special theory of relativity- Resnick
2. Waves, Mechanics & Oscillations- S B Puri

Mark distribution for setting Question paper.

Unit/ chapter	Title	Marks
1	Frames of reference.	12
2	Conservation of Energy and Momentum	19
3	Relativity	18
4	Oscillation and Waves	15
5	Introduction to Modern Physics	15
<i>Total Marks *</i>		79

*Total marks include that for choice of questions in sections A, B and C in the question paper.

Semester 4 | Complementary Course IV
PHY4C04: Electricity, Magnetism and Nuclear physics
54 Hours (Credit - 3)

	Course Outcome	CL	KC	Class Sessions allotted
CO1	Understand the basic ideas of static and current electricity	U	C	20
CO2	Understand the concepts of magnetism	U	C	12
CO3	Describe the fundamental concepts of nuclear physics	U	C	12
CO4	Understand the basic ideas of cosmic rays and elementary particles	U	C	10

Unit 1 Electrostatics

10 Hrs

Coulomb's law between charges- Electric field- field lines- Electric potential-Gauss's law and applications of Gauss's law to find field due to plane sheets of charge- Electrostatic shielding (Illustrate practical application) –Dielectrics- capacitors: A parallel plate capacitor, Energy of a capacitor, capacitance of cylindrical and spherical capacitors. Capacitance of a parallel plate capacitor- partially filled with dielectric and when completely filled with dielectric.

Unit 2 Current electricity

10 Hrs

Drift velocity of charges- electric resistance- superconductivity (basic ideas)- Galvanometer- conversion of galvanometer in to Voltmeter and ammeter – potentiometer – determination of resistance- carey fosters bridge- temperature coefficient of resistance.

Unit 3 Magnetism

12 Hrs

Earths magnetism- magnetic elements- Dia magnets-paramagnets and ferromagnets, Hysteresis. Magnetic moment-Deflection magnetometer-Tan A, Tan B and Tan C- Searles vibration magnetometer- Tangent galvanometer.

Unit 4 Nuclear physics

12 Hrs

Nucleus and its properties- nuclear force- stability of nucleus- binding energy- nuclear fission- fusion- reactors- Nuclear bomb, Hydrogen bomb- Radio activity- α , β and γ radiations- half life and mean life- C_{14} dating- Effects of radiation- Nuclear waste disposal Particle accelerators- Linear accelerator- cyclotron

Unit 5 Cosmic rays and Elementary particles**10 Hrs**

Cosmic rays (primary and secondary)- cosmic ray showers- Elementary particles-Classifications- Leptons- Hadrons - Higgs boson- L H C- Origin of universe.

Books for study

1. Electricity and Magnetism-Murugesan
2. Nuclear Physics-D C Tayal

Reference books

1. Introduction to Electrodynamics-David J Griffith
2. Electricity and Magnetism – Arthur F Kip
3. Concepts of Modern physics – Arthur Beiser
4. Nuclear physics – Irvin Kaplan

Mark distribution for setting Question paper.

Unit/ chapter	Title	Marks
1	Electrostatics	15
2	Current electricity	15
3	Magnetism	17
4	Nuclear physics	17
5	Cosmic rays and Elementary particles	15
<i>Total Marks *</i>		79

*Total marks include that for choice of questions in sections A, B and C in the question paper.

LAB PROGRAMME FOR COMPLEMENTARY COURSES

(Lab examination will be conducted at the end of 4th semester)

The minimum number of experiments for appearing examination is 75% of total 24 experiments in the syllabus. Basic theory of the experiment must be shown at the time of Examination. **Students must submit a certified fair record at the time of Examination.** Number of Questions per session for the practical Examination shall be 8, and a minimum of 6 questions in the Question paper shall be set for the Examination at the centre.

Semester 1 to 4 | Complementary Course V

PHY4C05: PHYSICS PRACTICALS I

36 Hours in each semester × 4 (Credit - 5)

	Course Outcome	CL	KC	Class Sessions allotted
CO1	Apply and illustrate the concepts of properties of matter through experiments	Ap	P	36
CO2	Apply and illustrate the concepts of electricity and magnetism through experiments	Ap	P	36
CO3	Apply and illustrate the concepts of optics through experiments	Ap	P	36
CO4	Apply and illustrate the principles of electronics through experiments	Ap	P	36

List of Experiments

1. Characteristics of Diode and Zener diode
2. Liquid lens- Refractive index of liquid and glass
3. Torsion pendulum- Rigidity modulus
4. Spectrometer- Refractive index of the material of prism
5. Deflection Magnetometer- Moment of a magnet (Tan-A & Tan - B positions)
6. Potentiometer-Measurement of resistance
7. Young's modulus – Uniform bending –using optic lever
8. Static torsion – Rigidity modulus
9. Spectrometer- Grating- Normal incidence
10. Melde's string- Frequency of fork (Transverse and Longitudinal mode)- (Mass determination by equal oscillation method / digital balance)

11. Half wave rectifier and Full wave rectifier
12. Field along the axis of a circular coil
13. Deflection Magnetometer- Moment of a magnet (Tan-C)
14. Potentiometer- Conversion of Galvanometer in to voltmeter –calibration by standard voltmeter
15. Viscosity of liquid- Capillary flow- Variable pressure head method (Mass determination by equal oscillation method / digital balance)
16. Logic gates – Verification of truth table
17. Carey Fosters bridge- Resistivity of the material of wire
18. Surface Tension-Capillary rise method - Radius by microscope.
19. Young's modulus of a cantilever- Pin and microscope method
20. Potentiometer-Calibration of low range voltmeter
21. Moment of inertia of fly wheel
22. Tangent galvanometer – Reduction factor
23. Scarle's vibration magneto meter – Comparison of moments
24. Newton's rings- Wavelength of sodium light

Books of Study:

1. Electronics lab manual- K A Navas (vol 1 &2)
2. B.Sc Practical Physics- C L Arora

Reference book:

3. Practical Physics- S L Gupta & V Kumar

MODEL QUESTION PAPERS

**B. Sc Physics Core
SEMESTER 1**

MODEL QUESTION PAPER I

Name.....

Reg. No.....

FIRST SEMESTER B.Sc. DEGREE EXAMINATION 20.....
(CBCSS-UG)

Core Course – Physics: PHY1B01 – MECHANICS-I

Time: 2 Hrs

Maximum: 60 Marks

The symbols used in this question paper have their usual meanings

Section A – Short Answer type.

(Answer all questions in two or three sentences, each correct answer carries a maximum of 2 marks)

1. What is meant by an operational definition? Give an example.
2. What is a fictitious force? How it is related to the apparent force on a system?
3. What is a central force? Show that the work done by the central force is independent of the path.
4. Name the fundamental forces in nature and compare their strengths
5. State and explain Newton's law of gravitation
6. State and explain work energy theorem
7. What are conservative forces? Give examples
8. Sketch and explain the energy diagram of a two atom system
9. Show that angular momentum is conserved for a particle in central force motion
10. State and prove parallel axis theorem
11. What is moment of Inertia? How it is related to angular momentum?
12. Find the moment of inertia of a ring of radius 'R' and mass 'M' about an axis passing through the center and perpendicular to the plane of the ring.

(Ceiling – 20)

Section B – Paragraph / Problem type.

(Answer all questions in a paragraph of about half a page to one page, each correct answer carries a maximum of 5 marks)

13. What is the fundamental difference between Newtonian Mechanics and Lagrangian/Hamiltonian formulations of Mechanics? Explain the areas where Newtonian mechanics fail.
14. A Drum Major's Baton consists of two masses m_1 and m_2 separated by a thin rod of length l . the baton is thrown into air. Find the centre of mass and equation of motion for centre of mass of the baton
15. A 5kg mass moves under the influence of a force $F=(4t^2\mathbf{i}-3t\mathbf{j})\text{N}$. It starts from the origin at $t=0$. Find its velocity and position at $t=1\text{s}$
16. Obtain an expression for moment of inertia of a uniform thin hoop of mass m and radius r about an axis passing through the centre and perpendicular to the plane of the hoop
17. Show that the acceleration of the masses m_1 and m_2 suspended over a pulley of mass m_p in an Atwood's machine is $a=(m_1-m_2)g/(m_1+m_2+m_p/2)$
18. A uniform drum of radius b and mass M rolls down a plane inclined at an angle θ . Find its acceleration along the plane. The moment of inertia of the drum about its axis is $I_0=Mb^2/2$
19. Discuss the general steps involved in applying Newton's laws to a system. Consider the case of two bodies placed on a table top as an example..

(Ceiling – 30)

SECTION C – Essay type

(Essays - Answer in about two pages, any one question. Answer carries 10 marks)

20. Define potential energy. Obtain potential energies of a uniform force field and an inverse square force
21. State the law of conservation of angular momentum. Prove that the angular momentum of a rigid body is equal to the sum of the angular momentum about the centre of mass and the angular momentum of the centre of mass about the origin. (1 · 10 = 10)

MODEL QUESTION PAPER 2

Name.....

Reg. No.....

FIRST SEMESTER B.Sc. DEGREE EXAMINATION 20.....

(CBCSS-UG)

Core Course – Physics: PHY1B01 - MECHANICS-I

Time: 2 Hrs

Maximum: 60 Marks

The symbols used in this question paper have their usual meanings

Section A – Short Answer type.

(Answer all questions in two or three sentences, each correct answer carries a maximum of 2 marks)

1. What is meant by 'isolating a body' in Mechanics?. Is it possible to isolate physical systems?
2. What is friction? What is the expression for the maximum value of friction?
3. What is Chasles' theorem?
4. Describe a conical pendulum
5. What are fictitious forces? Give an example
6. Describe the dynamics of a spring – block system
7. Explain the term centre of mass.
8. Write on the work - energy theorem in one dimension
9. State and explain the parallel axis theorem
10. Give an example of the law of conservation of angular momentum
11. Find the MI of a thin uniform stick of mass 'M' and length 'L' about an axis passing through the midpoint and perpendicular to the length.
12. Explain the terms (a) Physical pendulum (b) Radius of gyration

(Ceiling – 20)

Section B – Paragraph / Problem type.

(Answer all questions in a paragraph of about half a page to one page, each correct answer carries a maximum of 5 marks)

13. Show that under the action of viscous forces, velocity decreases exponentially with time?

14. Using this theorem, obtain the expression for the displacement of a one-dimensional harmonic oscillator.
15. Find the expression for the maximum value of ' θ ' at which a block begins to slide on a wedge with friction.
16. Show that angular momentum is conserved in motion under central forces.
17. Explain the principle of the Atwood's machine.
18. (a) A particle of mass '2Kg' experiences two forces, $F_1 = 5i + 8j + 7k$ and $F_2 = 3i - 4j + 3k$. What is the acceleration of the particle? (b) An object of mass '2Kg' is resting on the floor. The coefficient of static friction between the object and the floor is ' $\mu = 0.8$ '. What is the minimum force required to move the object?
19. A bead of mass ' m ' slides without friction on a rod that is made to rotate at a constant angular velocity ' ω '. Neglect gravity. Find the possible motion of the bead. (Find r as function of ' ω ' and time ' t '. Take r_0 as the initial distance of the bead from the pivot.)

(Ceiling – 30)

SECTION C – Essay type

(Essays - Answer in about two pages, any one question. Answer carries 10 marks)

20. (a) Discuss the general steps to analyze a physical problem using Newton's Second Law, and explain with the example of two blocks (one above the other) at rest on a table top.
 (b) Find the force on the P^{th} compartment of a train having a total of N compartments, each having masses ' M ' and pulled with a force ' F '.
21. Define the term potential energy. Describe the potential energy of a system moving under a uniform force and under an inverse square law force. (1 * 10 = 10)

**B. Sc Physics Core
SEMESTER 2**

MODEL QUESTION PAPER 1

Name.....

Reg. No.....

SECOND SEMESTER B.Sc. DEGREE EXAMINATION 20.....
(CBCSS-UG)

Core Course – Physics: PHY2B02 - MECHANICS II

Time: 2 Hrs

Maximum: 60 Marks

The symbols used in this question paper have their usual meanings

Section A – Short Answer type.

(Answer all questions in two or three sentences, each correct answer carries a maximum of 2 marks)

1. State the principle of relativity.
2. What are dispersive and nondispersive sinusoidal waves?
3. Why do we obtain slightly different result in calculating the velocity of sound waves in air using Newton's model?
4. What are the two types of wave motion?
5. What is the Bandwidth time-interval product describing a pulse.
6. State Kepler's first law.
7. What are Galilean transformations?
8. How do the same notes of same fundamental frequency from different musical instruments differ?
9. What is the advantage of reduced mass?
10. Explain the terms: apogee and perigee.
11. What are Lorentz transformations?
12. What is Q factor of an oscillator? (Ceiling – 20)

Section B – Paragraph / Problem type.

(Answer all questions in a paragraph of about half a page to one page, each correct answer carries a maximum of 5 marks)

13. A damped harmonic oscillator is subjected to a sinusoidal driving force whose frequency is altered but amplitude kept constant. It is found that the amplitude of the oscillator increases

from 0.02mm at very low driving frequency to 8.0mm at a frequency of 100 cps. Obtain the values of a) quality factor b) damping factor c) half-width of the resonance curve.

14. State and prove Kepler's third law.
15. Show that for an elliptical orbit $e = (r_{\max} - r_{\min}) / (r_{\max} + r_{\min})$ where the letters have their usual meanings.
16. What are stationary satellites? Calculate the height at which such a satellite must revolve in its orbit around the earth.
17. What is a Foucault pendulum? Calculate the time it will take the plane of oscillation of a Foucault's pendulum to turn through 90° at a point where the co-latitude is 60° .
18. Discuss the following terms: a) phase velocity b) group velocity.
19. For a continuous string, obtain an expression for reflection coefficient in terms of impedances.
(Ceiling - 30)

SECTION C – Essay type

(Essays - Answer in about two pages, any one question. Answer carries 10 marks)

20. What is a pulse? Discuss Fourier analysis of a non-periodic function with suitable plots.
21. Discuss the origin of fictitious forces in rotating coordinate systems. Hence discuss the geographical consequences of Coriolis forces on earth. (1 * 10 = 10)

MODEL QUESTION PAPER 2

Name.....

Reg. No.....

SECOND SEMESTER B.Sc. DEGREE EXAMINATION 20.....
(CBCSS-UG)

Core Course – Physics: PHY2B02 - MECHANICS II

Time: 2 Hrs

Maximum: 60 Marks

The symbols used in this question paper have their usual meanings

Section A – Short Answer type.

(Answer all questions in two or three sentences, each correct answer carries a maximum of 2 marks)

1. State the principle of equivalence.
2. What is a central force?
3. What is a Foucault's pendulum?
4. Write the equation of a forced damped harmonic oscillator and describe the terms involved.
5. State two important properties of travelling waves.
6. Explain: a) phase velocity b) group velocity.
7. What is a pulse?
8. What is meant by reduced mass of system?
9. For motion in an inverse square force field, state the conditions in terms of the total energy E for the path to be a) an ellipse b) a parabola.
10. Define an inertial frame of reference.
11. What are stationary satellites?
12. A particle of mass 100 gm lies in a potential field $V = 32x^2 + 200$ ergs/gm. What is the frequency of oscillation? (Ceiling – 20)

Section B – Paragraph / Problem type.

(Answer all questions in a paragraph of about half a page to one page, each correct answer carries a maximum of 5 marks)

13. Discuss Newton's model to determine the velocity of sound in air? Account for the correction required to obtain observed result.
14. What are the general properties of a central force motion?

15. State and explain Kepler's laws.
16. What are uniformly accelerating systems? Discuss the origin of fictitious forces in such systems.
17. Obtain Snell's law of refraction.
18. What are Fourier integrals?
19. For a particle of mass m in a central force field, write the velocity of the particle in polar coordinates. Hence obtain the principle of conservation of energy. (Ceiling – 30)

SECTION C – Essay type

(Essays - Answer in about two pages, any one question. Answer carries 10 marks)

20. What is a rotating coordinate system? Obtain expression for acceleration relative to rotating coordinates. Hence discuss Coriolis forces and centrifugal forces.
21. Write down and solve the differential equation of a damped harmonic oscillator subjected to a sinusoidal force and obtain expressions for its maximum amplitude and quality factor. (1 + 10 = 10)

**B. Sc Physics Core
SEMESTER 3**

MODEL QUESTION PAPER 1

Name.....

Reg. No.....

THIRD SEMESTER B.Sc. DEGREE EXAMINATION 20.....
(CBCSS-UG)

Core Course – Physics: PHY3B03 - ELECTRODYNAMICS I

Time: 2 Hrs

Maximum: 60 Marks

The symbols used in this question paper have their usual meanings

Section A – Short Answer type.

(Answer all questions in two or three sentences, each correct answer carries a maximum of 2 marks)

1. What does the operator ∇ stand for in Cartesian coordinates?
2. Express the elemental displacements and volume in spherical polar coordinates.
3. Discuss the analogy between density of electric flux and intensity of electric field due to a point charge.
4. What is the advantage of scalar potential formulation in electrostatics?
5. Show that electric charge density inside a conductor is zero.
6. Get a relation between electric susceptibility and polarizability of a linear dielectric.
7. What is Lorentz' force?
8. Show that surface current density is the product of charge density and velocity of charges?
9. Write down the differential form of Ampere's circuital theorem from the integral form.
10. Explain magnetic vector potential.
11. How magnetic dipoles are generated in specimen placed in a magnetic field?
12. How volume bound current density J_b is related to susceptibility and free current density

J_f

(Ceiling – 20)

Section B – Paragraph / Problem type.

(Answer all questions in a paragraph of about half a page to one page, each correct answer carries a maximum of 5 marks)

13. Obtain the relation between three electric vectors.
14. Discuss about the bound charges in a polarized dielectric medium.

15. Derive the law of refraction for the electric lines of force moving from a dielectric medium having dielectric constant K_1 to another medium of constant K_2 .
16. Discuss briefly about the bound currents in a magnetized medium.
17. A dielectric slab of thickness 5mm and dielectric constant 3 is placed between two oppositely charged plates. If the field outside the dielectric is 10^5 V/m, calculate (i) polarization in the dielectric, (ii) electric displacement and (iii) bound charges in the dielectric.
18. Find the magnetic flux density at the centre of a square wire loop of side 10cm, carrying 1 Ampere current.
19. An electron beam passes undeviated normal to a crossed electric and magnetic field of magnitudes 4×10^4 V/m and 6×10^{-3} tesla. Find the velocity of electron leaving out undeviated from the crossed fields and also find the radius of electron path when the electric field is switched off. (Ceiling – 30)

SECTION C – Essay type

(Essays - Answer in about two pages, any one question. Answer carries 10 marks)

20. State and prove Gauss's law and use it find the electric field due to a charged spherical conductor and charged cylindrical conductor.
21. Briefly explain the domain theory and discuss the characteristics of ferromagnetic material with the help of hysteresis loop. (1 · 10 = 10)

MODEL QUESTION PAPER 2

Name.....

Reg. No.....

THIRD SEMESTER B.Sc. DEGREE EXAMINATION 20.....
(CBCSS-UG)

Core Course – Physics: PHY3B03 - ELECTRODYNAMICS I

Time: 2 Hrs

Maximum: 60 Marks

The symbols used in this question paper have their usual meanings

Section A – Short Answer type.

(Answer all questions in two or three sentences, each correct answer carries a maximum of 2 marks)

1. Prove law of cosines.
2. What is the Physical interpretation of gradient of a scalar field?
3. State Divergence theorem.
4. Derive differential form of Gauss's law in electrostatics.
5. Obtain Laplace's equation.
6. Draw a graph showing the variation of intensity of electric field due to a uniformly charged spherical conductor with distance.
7. Write the electrostatics boundary conditions regarding \underline{D} and V .
8. Get the relation between electric susceptibility and dielectric constant of a linear dielectric medium.
9. How $\nabla \cdot \underline{B}$ leads to conclusion that magnetic monopoles cannot exist.
10. Derive cyclotron formula.
11. Show that no work is done by magnetic field, on a charged particle moving in it.
12. Explain the magnetic saturation of a ferromagnetic material based on competing magnetic domains? (Ceiling – 20)

Section B – Paragraph / Problem type.

(Answer all questions in a paragraph of about half a page to one page, each correct answer carries a maximum of 5 marks)

13. Prove the fundamental theorem of *Curl* using the function $\underline{F} = (2xz + 3y^2)\hat{j} + 4yz^2\hat{k}$ and square surface of unit side with one corner coinciding with origin.

14. Using Gauss's law find the electric field inside and outside a spherical shell of radius R , which carries uniform charge density ρ .
15. Describe polar and non polar dielectric materials.
16. A sphere of linear dielectric material is placed in a uniform electric field E_0 . Find the new field inside the sphere.
17. Three point charges each of $100\mu\text{C}$ are placed at the three corners of a square of side 10 cm. Find the total potential energy of the system, when a fourth charge of same magnitude is brought to the last corner of the square.
18. Find the capacitance of two concentric spherical metallic shells, with inner radius a and outer radius b .
19. Calculate the intensity of magnetization inside a metal rod if a magnetizing field results in a magnetic field of 3×10^{-4} weber/m² induced in vacuum and a magnetic field of 1.5×10^{-3} weber/m² induced in the material of the rod. (Ceiling – 30)

SECTION C – Essay type

(Essays - Answer in about two pages, any one question. Answer carries 10 marks)

20. A slab of linear dielectric material is partially inserted between the plates of a charged parallel plate capacitor. Derive an expression for force acting on the slab.
21. Discuss the motion of electric charges in cyclotron and derive expressions for cyclotron frequency and maximum energy acquired by charge from cyclotron.

(1 · 10 = 10 marks)

**B. Sc Physics Core
SEMESTER 4**

MODEL QUESTION PAPER - 1

Name.....

Reg. No.....

FOURTH SEMESTER B.Sc. DEGREE EXAMINATION 20.....
(CBCSS-UG)

Core Course – Physics: PHY4B04 - ELECTRODYNAMICS II

Time: 2 Hrs

Maximum: 60 Marks

The symbols used in this question paper have their usual meanings

Section A – Short Answer type.

(Answer all questions in two or three sentences, each correct answer carries a maximum of 2 marks)

1. Write down the differential and integral forms of Faraday's law
2. Give Maxwell's modification of Ampere's law.
3. How refractive index of a medium can be obtained from basic electro-magnetic constants.
4. Explain polarization of electromagnetic waves.
5. Define intensity of e.m.waves and how it is related to Poynting vector.
6. Discuss the growth of current in a CR circuit?
7. What are the conditions for a moving coil galvanometer to be ballistic?
8. Define the r.m.s value of e.m.f and write how it is related to peak value of e.m.f.
9. Compare series LCR resonant circuit and parallel LCR resonant circuit.
10. Draw the circuit diagram for obtaining balance using Anderson's bridge.
11. What is an ideal constant voltage source?
12. State Thevenin's theorem (Ceiling – 20)

Section B – Paragraph / Problem type.

(Answer all questions in a paragraph of about half a page to one page, each correct answer carries a maximum of 5 marks)

13. State Lenz's law. Obtain the expression for energy stored in an inductor.
14. Find the reflection coefficient of an electromagnetic wave falling normally on a boundary.
15. Draw and explain circuit diagram for decay of current in L-R circuit.
16. Obtain the classical wave equation.

17. A square wire of side 10 cm is perpendicular to a magnetic field 4×10^{-3} Tesla. (a) What is the magnetic flux through the loop? (b) If the field drops to zero in 0.1 second, what is the average e.m.f induced in the circuit during this time.
18. The time averaged Poynting vector of Sun's e.m. radiation received at the upper surface of earth's atmosphere, $S = 1.35 \times 10^3 \text{ W/m}^2$. Assuming that waves are plane & sinusoidal what are the amplitudes of electric and magnetic fields.
19. A pure resistance of $100\ \Omega$ is in series with a pure inductance of 5 henry and a variable capacitance. The combination is connected to a 100V, 50Hz supply. At what value of capacitance will the current in the circuit be in phase with the applied voltage? Calculate the current in this condition. What will be the potential difference across the resistance, inductance and capacitance at that time? (Ceiling – 30)

SECTION C – Essay type

(Essays - Answer in about two pages, any one question. Answer carries 10 marks)

20. A plane polarized monochromatic wave of angular frequency ω passes normally through a boundary between two linear non conducting media. Discuss the phenomenon of the reflection and transmission.
21. Define the charge sensitiveness of BG. With necessary theory, describe an experiment to determine the charge sensitiveness of BG using standard condenser and HMS.

(1 · 10 = 10 marks)

MODEL QUESTION PAPER - 2

Name.....

Reg. No.....

FOURTH SEMESTER B.Sc. DEGREE EXAMINATION 20.....
(CBCSS-UG)

Core Course – Physics: PHY4B04 - ELECTRODYNAMICS II

Time: 2 Hrs

Maximum: 60 Marks

The symbols used in this question paper have their usual meanings

Section A – Short Answer type.

(Answer all questions in two or three sentences, each correct answer carries a maximum of 2 marks)

1. Discuss Faraday's laws of electromagnetic induction.
2. Write down general wave equation. Give its solution.
3. Write the boundary conditions for E , B , D & H , at a boundary between two different media.
4. What is radiation pressure? Write relation connecting intensity and radiation pressure of an electromagnetic wave.
5. Write down Poynting theorem
6. Write down Maxwell's equations inside matter.
7. Discuss the growth of current in a L-R circuit?
8. Write down the characteristics of a dead beat moving coil galvanometer.
9. What is meant by the logarithmic decrement in a moving coil galvanometer?
10. What is the power factor in inductor-resistor series circuit?
11. What you mean by Q-factor in a series resonant circuit.
12. State superposition theorem. (Ceiling – 20)

Section B – Paragraph / Problem type.

(Answer all questions in a paragraph of about half a page to one page, each correct answer carries a maximum of 5 marks)

13. Give brief account of magnetic charge.
14. Explain mutual inductance and get Neumann's formula for the same.
15. How can a voltage source be converted into equivalent current source and vice versa.

16. Describe with vector diagram, how the impedance of an LCR series circuit is expressed in terms of j -operator.
17. If the charge on capacitor of capacitance 2 microfarad is leaking through a high resistance of 100 megaohms is reduced to half its maximum value, calculate the time of leakage.
18. An alternating potential of 100 volt and 50 hertz is applied across a series circuit with $L=5$ henry, $R=100$ ohm and a variable C . At what value of C , will current in the circuit be in phase with applied voltage? Calculate current in this condition. What will be the potential difference across R , L and C at that time?
19. Show that at maximum power transfer, efficiency is only 50%. (Ceiling – 30)

SECTION C – Essay type

(Essays - Answer in about two pages, any one question. Answer carries 10 marks)

20. Explain how Maxwell modified Ampere's theorem. Derive Maxwell's equation in matter.
21. Describe with theory, the Anderson's method to determine self inductance of a coil.

(1 · 10 = 10 marks)

**B. Sc Physics Core
SEMESTER 5**

MODEL QUESTION PAPER - 1

Name.....

Reg. No.....

FIFTH SEMESTER B.Sc. DEGREE EXAMINATION 20.....

(CBCSS-UG)

Core Course – Physics: PHY5B06 - COMPUTATIONAL PHYSICS

Time: 2 Hrs

Maximum: 60 Marks

The symbols used in this question paper have their usual meanings

Section A – Short Answer type.

(Answer all questions in two or three sentences, each correct answer carries a maximum of 2 marks)

1. Write an algorithm to accept two numbers compute the sum and print the result.
2. What is the difference between a compiler and interpreter in a computer?
3. Name the different data types in Python.
4. 12. What will be the output of the program?

```
>>> a = 4.0
```

```
>>> x = 3.0
```

```
>>> y = (x+ a/x)/2
```

5. What is a tuple? How literals of type tuple are written? Give example.
6. What is a list? How lists are different from tuples?
7. Write a program to create a 1D array of numbers from 0 to 9 using numpy
8. Write the Python command to display the x and y axis label and title in a graph.
9. Write a Python function to calculate the two parameters of least-squares fitting.
10. Decreasing the step size improves your result linearly in Euler's method. Justify.
11. How second order Runge-Kutta method is related to Euler's method?
12. What are the advantages of numerical methods over analytical methods? (Ceiling – 20)

Section B – Paragraph / Problem type.

(Answer all questions in a paragraph of about half a page to one page, each correct answer carries a maximum of 5 marks)

13. a) Write the syntax for the control statements if..elif...if and while in Python.
b) Write a program that tests whether a number is prime or not using while and if...else statements.
14. Write a Python program to simulate two dimensional projectile motion of a body moving under gravity using Euler's method.

15. By the method of least squares, find the straight line that best fits the following data:

X	1	2	3	4	5
Y	23	29	17	37	41

16. Write a program to sum the series: $\sin(x) = x - (x^3/3!) + (x^5/5!) - (x^7/7!) + \dots$

17. Write a program that plots the motion of a mass oscillating at the end of a spring. The force on the mass should be given by $F = -mg + kx$.

18. Find all the roots of $\sin(x)$ between 0 and 10, using Newton-Raphson method.

19. Write a program to simulate the motion of a body projected horizontally from a height on earth. (Ceiling – 30)

SECTION C – Essay type

(Essays - Answer in about two pages, any one question. Answer carries 10 marks)

20. Explain Euler's method of finding solution of a differential equation. Write a program to simulate by tabulation a free fall body under gravity using Euler's method.

21. Deduce Newton's forward interpolation formula and hence obtain the expressions for dy/dx and d^2y/dx^2 and find the value of first and second derivative at $x=1.5$.

x	1	2	3	4	5
y	1	4	9	16	25

(1 - 10 = 10 marks)

MODEL QUESTION PAPER - 2

Name.....

Reg. No.....

FIFTH SEMESTER B.Sc. DEGREE EXAMINATION, 20.....

(CBCSS-UG)

Core Course – Physics: PHY5B06 - COMPUTATIONAL PHYSICS

Time: 2 Hrs

Maximum: 60 Marks

The symbols used in this question paper have their usual meanings

Section A – Short Answer type.

(Answer all questions in two or three sentences, each correct answer carries a maximum of 2 marks)

1. Write a Python program to add an element 10 to a list $x = [1, 2, 3]$ and to print that element.
2. What will be the result if the following Python code is executed?
for n in range(1000) :
 if n% 100 == 0 :
 print 'step' n
3. What is meant by indentation and what is its importance in Python?
4. Give an example for using if, elif , else statement.
5. Write a program to make a list of lists and convert it to an array.
6. Write a program to make a 3×3 matrix and multiply it by 5 and print the result.
7. Using polar () function write a program to plot a circle of radius 5 cm.
8. Write a program using linspace to plot $\sin^2 x$, $\cos x$, $\sin x^2$
9. What are functions and modules in Python?
10. Write the syntax to append, insert, del, remove an element from a list.
11. Illustrate file input and file output using an example.
12. Python has developed as an open source project. Justify this statement

(Ceiling – 20)

Section B – Paragraph / Problem type.

(Answer all questions in a paragraph of about half a page to one page, each correct answer carries a maximum of 5 marks)

13. Write a Python program to integrate $f(x) = x^3$ using Simpson's rule
14. Write a Python program to trace the path of a projectile moving through air and experiencing a resistive force proportional to the square of velocity.

15. Find the value of y for $x = 4.2$ from the following table using Newton's forward interpolation formula

X	4	4.5	5	5.5	6	6.5
Y	18	22.25	27	32.25	39	44

16. Write a program to fit a straight line by least square fit method from a set of data from user.
17. The table given below reveals the observation taken by a student for a particular experiment. Write a python program to find the first and second derivatives at $x=1.5$ from the tabulated set of values.

X	1	2	3	4	5
Y	1	4	9	16	25

18. What are the different loop control statements available in Python? Explain with suitable examples.
19. Write the syntax for accessing, adding and deleting an element from a list and illustrate the use of user-defined functions in Python. (Ceiling – 30)

SECTION C – Essay type

(Essays - Answer in about two pages, any one question. Answer carries 10 marks)

20. a) Explain second order Runge-Kutta method for solving differential equations.
b) Write a program to simulate a two-dimensional projectile motion using Euler method in a table.
21. a) Write a program to simulate in a table by numerical method for the motion of a body falling in a viscous medium.
b) Write a python program to find a root of the equation x^3-x-11 by Newton-Raphson method. (1 · 10 = 10 marks)

MODEL QUESTION PAPER - 1

Name.....

Reg. No.....

FIFTH SEMESTER B.Sc. DEGREE EXAMINATION 20.....
(CBCSS-UG)

Core Course – Physics: PHY5B07 – QUANTUM MECHANICS

Time: 2 Hrs

Maximum: 60 Marks

The symbols used in this question paper have their usual meanings

Section A – Short Answer type.

(Answer all questions in two or three sentences, each correct answer carries a maximum of 2 marks)

1. What is meant by work function?
2. Write down the Planck Radiation formula
3. State and explain correspondence principle
4. Mention any two deficiencies of the Bohr model of atom
5. Explain the term probability amplitude
6. What is meant by eigen function and eigen value? Give an example
7. Explain zero point energy of a harmonic oscillator
8. Describe quantum tunneling
9. Explain Zeeman effect
10. Write down the admissibility conditions for a function to represent a wave function
11. Explain pair production
12. What is meant by normalization? (Ceiling – 20)

Section B – Paragraph / Problem type.

(Answer all questions in a paragraph of about half a page to one page, each correct answer carries a maximum of 5 marks)

13. Explain Einstein's photoelectric equation
14. Describe the Frank – Hertz experiment
15. Explain the concept of a wave packet and explain the terms phase velocity and group velocity
16. Derive Schrödinger's time independent equation from the time dependent one

17. The work function for Tungsten is 4.52 eV. Radiation of wavelength 198 nm is incident on a piece of Tungsten. Find (a) the cutoff wavelength for Tungsten (b) the stopping potential and (c) maximum kinetic energy of photoelectrons
18. Protons of kinetic energy 1 GeV are diffracted by Oxygen nuclei of radius 3 fm. Calculate the expected angles where the first three diffraction minima should appear
19. An electron is trapped in a one dimensional region of width 1×10^{-10} m. Find the energies of the ground state and the first excited state. If the electron happens to be in the second excited state and then drops down to the ground state, find the energy emitted.

(Ceiling – 30)

SECTION C – Essay type

(Essays - Answer in about two pages, any one question. Answer carries 10 marks)

20. Obtain the expression for wavelength change in Compton scattering
21. Describe the quantum theory of the Hydrogen atom. (1 · 10 = 10 marks)

MODEL QUESTION PAPER - 2

Name.....

Reg. No.....

FIFTH SEMESTER B.Sc. DEGREE EXAMINATION 20.....
(CBCSS-UG)

Core Course – Physics: PHY5B07 – QUANTUM MECHANICS

Time: 2 Hrs

Maximum: 60 Marks

The symbols used in this question paper have their usual meanings

Section A – Short Answer type.

(Answer all questions in two or three sentences, each correct answer carries a maximum of 2 marks)

1. What is photoelectric effect? Write down Einstein's photoelectric equation
2. Explain ultraviolet catastrophe
3. Compare Rutherford model of the atom with the Bohr model
4. Explain the probability interpretation of wave function
5. What is space quantization?
6. State and explain Heisenberg's uncertainty relation
7. Write down the Schrödinger equation for a free particle and explain its solution
8. Explain the motion of a particle incident on a potential energy step
9. What is Bohr magneton?
10. Explain the fine structure of Hydrogen spectrum
11. What are the properties of the azimuthal quantum number?
12. Explain the term probability amplitude

(Ceiling – 20)

Section B – Paragraph / Problem type.

(Answer all questions in a paragraph of about half a page to one page, each correct answer carries a maximum of 5 marks)

13. Explain Compton effect
14. Write down the Schrodinger equation of the Hydrogen atom and explain the angular momentum quantum number.
15. Describe the quantum theory of motion of a particle in a two dimensional potential well.
16. Explain the theory of the quantum harmonic oscillator.
17. X-rays of wavelength 0.24 nm are Compton – scattered and the scattered beam is observed at an angle of 60° with the incident direction. Find (a) the wavelength of scattered rays (b)

the energy of scattered X-ray photons (c) the kinetic energy of scattered electrons and (d) the direction of motion of the scattered electrons.

18. An electron is confined to a region of space by a spring-like force of force constant $k = 95.7 \text{ eV/m}^2$. Find the probability to find the electron in a narrow interval of width 0.004 nm located halfway between the equilibrium position and the classical turning point.
19. Obtain the relation between phase velocity and group velocity for de Broglie waves.

Certain ocean waves travel with a phase velocity of $v_p = \sqrt{\frac{g\lambda}{2\pi}}$. Find their group velocity

(Ceiling – 30)

SECTION C – Essay type

(Essays - Answer in about two pages, any one question. Answer carries 10 marks)

20. Describe the quantum theory of a particle confined in a one dimensional box
21. Explain the Frank – Hertz experiment. What is its significance for the model of an atom?

(1 × 10 = 10 marks)

MODEL QUESTION PAPER - 1

Name.....

Reg. No.....

FIFTH SEMESTER B.Sc. DEGREE EXAMINATION 20.....

(CBCSS-UG)

Core Course – Physics: PHY5B08 - OPTICS

Time: 2 Hrs

Maximum: 60 Marks

The symbols used in this question paper have their usual meanings

Section A – Short Answer type.

(Answer all questions in two or three sentences, each correct answer carries a maximum of 2 marks)

1. State Fermat's principle
2. What are the conditions for interference?
3. What is meant by coherence?
4. Write down the conditions for maxima and minima in reflected light for Newton's rings experiment.
5. Explain cosine law
6. Write the expression for intensity distribution in Fraunhofer diffraction by a circular aperture.
7. Define resolving power of a diffraction grating.
8. Mention any two differences between zone plate and a convex lens.
9. List out the differences between positive and negative crystals.
10. Explain the terms plane of vibration and plane of polarization.
11. Write any two applications of holography.
12. Give two differences between step index and graded index fibres. (Ceiling – 20)

Section B – Paragraph / Problem type.

(Answer all questions in a paragraph of about half a page to one page, each correct answer carries a maximum of 5 marks)

13. Derive the laws of reflection from Fermat's principle.
14. Explain the colour of thin films

15. An air wedge apparatus of angle 0.01 radian is illuminated by light of wavelength 6000 Angstroms. At what distance from the edge of the wedge will be 10th dark fringe observed?
16. A plane grating has 15000 lines per inch. Find the angle of separation of the 5048 Angstrom and 5016 Angstrom lines of Helium in the second order spectrum.
17. The diameter of the first ring of a zone plate is 1.1 mm. If light of wavelength 6000 Angstrom is incident on the zone plate, where should the screen be placed so that a bright spot is obtained?
18. The critical angle for total internal reflection from water is 48°. Find the polarization angle and the angle of refraction corresponding to the polarization angle.
19. Calculate the least thickness of a calcite plate which would convert incident plane polarized light into circularly polarized light. Given $\mu_o = 1.658$, $\mu_e = 1.486$ for calcite and wavelength of light used is 5890 Angstrom. (Ceiling – 30)

SECTION C – Essay type

(Essays - Answer in about two pages, any one question. Answer carries 10 marks)

20. Describe the structure and working of Michelson's interferometer
21. Explain the structure of a Nicol prism. Describe how it is used as an analyzer and as a polarizer. (1 · 10 = 10 marks)

MODEL QUESTION PAPER - 2

Name.....

Reg. No.....

FIFTH SEMESTER B.Sc. DEGREE EXAMINATION 20.....
(CBCSS-UG)

Core Course – Physics: PHY5B08 - OPTICS

Time: 2 Hrs

Maximum: 60 Marks

The symbols used in this question paper have their usual meanings

Section A – Short Answer type.

(Answer all questions in two or three sentences, each correct answer carries a maximum of 2 marks)

1. Why does ordinary light never form stable interference pattern?
2. Write the cosine law for interference by division of amplitude
3. Why do the fringes in air wedge setup have the form of straight lines?
4. Why is the centre of interference pattern due to white light seen to be white?
5. What is the nature of the diffraction pattern produced by a circular aperture?
6. What are the differences between a zone plate and a convex lens?
7. Why half period zones are called so?
8. Differentiate between uniaxial and biaxial crystals and give an example for each
9. What is meant by circularly polarized light?
10. Explain the term birefringence
11. How is a hologram different from an ordinary photograph?
12. Define the term numerical aperture. (Ceiling – 20)

Section B – Paragraph / Problem type.

(Answer all questions in a paragraph of about half a page to one page, each correct answer carries a maximum of 5 marks)

13. Derive the laws of refraction from Fermat's principle
14. Explain pulse dispersion in optical fibres. How is it overcome in graded index fibres?
15. Find the radii of the first three transparent zones of a zone plate whose first focal length is 1 m for light of wavelength 5893 Angstrom
16. A half wave plate is designed for wavelength 3800 Angstrom. For what wavelength will it work as a quarter wave plate?

17. Newton's rings are observed in reflected light of wavelength 5.9×10^{-7} m. The diameter of the 10th dark ring is 0.5 cm. Find the radius of curvature of the lens and the thickness of air film at the position of the 10th dark ring.
18. Calculate the highest order of spectra with a plane transmission grating of 18000 lines per inch when light of 4500 Angstrom is used
19. Derive the expression for acceptance angle of an optical fibre. In an optical fibre, the core has a refractive index of 1.6 and the cladding has a refractive index of 1.3. Find the values of critical angle and acceptance angle for the fibre. (Ceiling – 30)

SECTION C – Essay type

(Essays - Answer in about two pages, any one question. Answer carries 10 marks)

20. Describe the experiment for determination of wavelength of light using Newton's rings arrangement.
21. Derive the grating equation for normal incidence. How is the diffraction grating used to find the wavelength of light? (1 - 10 = 10 marks)

MODEL QUESTION PAPER - 1

Name.....

Reg. No.....

FIFTH SEMESTER B.Sc. DEGREE EXAMINATION 20.....
(CBCSS-UG)

Core Course – Physics: PHY5B09 – ELECTRONICS (Analog and Digital)

Time: 2 Hrs

Maximum: 60 Marks

The symbols used in this question paper have their usual meanings

Section A – Short Answer type.

(Answer all questions in two or three sentences, each correct answer carries a maximum of 2 marks)

1. Derive the relation between α and β .
2. What is the peak inverse voltage?
3. Explain the stability factor for a transistor circuit.
4. Convert binary numbers 101010 and 111011 into decimal number.
5. Construct OR and AND gate by using NAND gate.
6. Define Ripple factor of a rectifier. What is its value for a full wave rectifier?
7. Draw the dc and ac equivalent circuit of a CE transistor amplifier.
8. Discuss the main characteristics of an ideal Operational Amplifier.
9. What do you mean by barrier potential of a PN junction?
10. Represent the following Boolean expression by K map $Y(A,B,C,D)=(A + B + \underline{C})$
 $(\underline{A} + \underline{C} + D)$.
11. The voltage gain of an amplifier without feedback is 2000. The feedback fraction is 0.01. Find the voltage gain of the amplifier if negative feedback is applied.
12. Give the Barkhausen condition for getting sustained oscillations. (Ceiling – 20)

Section B – Paragraph / Problem type.

(Answer all questions in a paragraph of about half a page to one page, each correct answer carries a maximum of 5 marks)

13. Explain voltage divider biasing with the help of a neat diagram.
14. For a differential circuit, the input is sinusoidal voltage of peak value 10 mV and frequency 1KHz. $R=100K\Omega$ and $C=0.1\mu F$. Find output
15. For the transistor amplifier shown in figure, $R_1 = 10 k\Omega$, $R_2 = 5 k\Omega$, $R_C = 1 k\Omega$, $R_E = 3 k\Omega$ and $R_L = 1 k\Omega$. Assume $V_{BE} = 0.7 V$

- i. Draw the dc load line
- ii. Determine the operating point
- iii. Draw ac load line

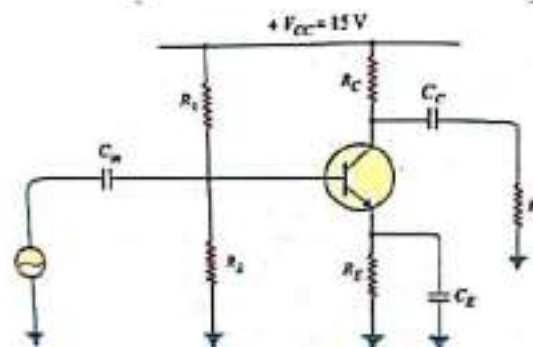

16. Explain 1's complement method of binary subtraction with example.
17. In a three section phase shift oscillator $R_1=R_2=R_3=20K\Omega$, and $C_1=C_2=C_3=0.01\mu F$. The resistors are connected in series and the capacitors are shunts. Find the frequency of oscillations
18. Explain Op-Amp integrator with a neat diagram.
19. Determine the output voltage for the op-amp circuit having $V_{in}=2.5mV$, $R_i=2k\Omega$, $R_f=200k\Omega$ and $\pm V_{cc}=\pm 9v$. (Ceiling - 30)

SECTION C – Essay type

(Essays - Answer in about two pages, any one question. Answer carries 10 marks)

20. Draw dc and ac equivalent circuits of a transistor amplifier. Derive an expression for the voltage gain from the ac equivalent circuit.
21. Explain the working of Colpitt's oscillator and Hartley oscillator with neat diagram. and write down the equation to find frequency of both circuits. (1 · 10 = 10 marks)

MODEL QUESTION PAPER - 2

Name.....

Reg. No.....

FIFTH SEMESTER B.Sc. DEGREE EXAMINATION 20.....
(CBCSS-UG)

Core Course – Physics: PHY5B09 - ELECTRONICS (Analog and Digital)

Time: 2 Hrs

Maximum: 60 Marks

The symbols used in this question paper have their usual meanings

Section A – Short Answer type.

(Answer all questions in two or three sentences, each correct answer carries a maximum of 2 marks)

1. What is the faithful amplification?
2. Write down the mantissa and exponent of the number 242506800
3. Explain the working of Zener diode as a voltage stabilizer.
4. State De Morgan's law.
5. Convert the following decimal in to binary a)(123.88)₁₀ b)(225)₁₀ c)(100.01)₁₀
6. What is the need for bias stability in a transistor circuits?
7. What is XNOR gate? Draw circuit diagram with truth table
8. Explain the working of a voltage doubler.
9. What are the advantages of using transformer in rectifier circuit
10. Subtract 01000111 from 01011000
11. Discuss the advantages of negative feedback in Amplifiers.
12. How is a JK flip-flop made to Toggle? (Ceiling – 20)

Section B – Paragraph / Problem type.

(Answer all questions in a paragraph of about half a page to one page, each correct answer carries a maximum of 5 marks)

13. A crystal diode having internal resistance $r_f = 20 \Omega$ used for half wave rectifier. If the applied voltage is equal to $50 \sin \omega t$ and load resistance $R_L = 800 \Omega$. Find
 - i. I_m , I_{dc} , I_{rms}
 - ii. Ac power input and dc power output
 - iii. Dc output voltage
 - iv. Efficiency of rectification

14. Derive the expression for collector current in common emitter connection. Draw the input and output characteristics.
15. Draw the DC load line and determine the operating point. Assuming the transistor to be of silicon

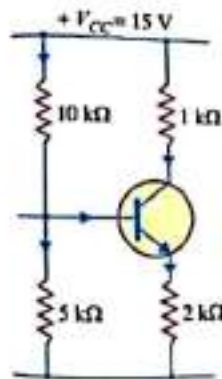

16. Explain with suitable diagram the inverting and non-inverting configurations of an Op-Amp and derive the expression for their voltage gain.
17. Explain the working of a RS flip-flop.
18. When negative voltage feedback is applied to an amplifier of gain 100, the overall gain falls to 50.
- Calculate the fraction of the output voltage feedback.
 - If this fraction is maintained, calculate the value of the amplifier gain required if the overall stage gain to be 75
19. Find the operating frequency of a Hartley's oscillator. If $L_1 = 100 \mu\text{H}$, $L_2 = 1 \text{mH}$, mutual inductance between the coils $M = 20 \mu\text{H}$ and $C = 20 \text{pF}$. Also determine the feedback fraction.
- (Ceiling – 30)

SECTION C – Essay type

(Essays - Answer in about two pages, any one question. Answer carries 10 marks)

20. With a neat sketch, explain the working of half wave rectifier. Derive the expression for efficiency and ripple factor.
21. What is an Op-Amp? State the characteristics of an ideal Op-Amp. Compare the operation of an inverting and non inverting amplifier using Op-Amp. (1 · 10 = 10 marks)

**B. Sc Physics Core
SEMESTER 6**

MODEL QUESTION PAPER - 1

Name.....

Reg. No.....

SIXTH SEMESTER B.Sc. DEGREE EXAMINATION 20.....
(CBCSS-UG)

Core Course – Physics: PHY6B10 – THERMODYNAMICS

Time: 2 Hrs

Maximum: 60 Marks

The symbols used in this question paper have their usual meanings

Section A – Short Answer type.

(Answer all questions in two or three sentences, each correct answer carries a maximum of 2 marks)

1. Comment on the concept of temperature and heat
2. Distinguish between intensive and extensive coordinates
3. What is the significance of PV diagram?
4. What is heat capacity? Write down the expression for heat capacity.
5. What is internal energy?
6. What is thermal efficiency? Write its expression?
7. State Carnot's theorem and corollary?
8. State Second law of thermodynamics? What is the significance of Second law of thermodynamics?
9. Distinguish between Carnot's engine and irreversible engine?
10. What is enthalpy?
11. What are Helmholtz and Gibbs function? Write down the formulae?
12. Write down the Clausius-Clayperon equation and its applications? (Ceiling – 20)

Section B – Paragraph / Problem type.

(Answer all questions in a paragraph of about half a page to one page, each correct answer carries a maximum of 5 marks)

13. Derive the equation for work done in an Adiabatic process.
14. State First law of thermodynamics? Derive differential form of First law?
15. Prove that $T_{S1} \leq T_{S2}$.
16. A Carnot's engine whose lower temperature heat (sink) is at 27°C has its efficiency 40 % .
What is the temperate of the heat sources? By how much should the temperature of the source be raised if the efficiency if to be raised to 70 %?

17. Calculate the work done when a gram molecule of an ideal gas expands isothermally at 27°C to double its original volume? ($R = 8.3$ joules/degree mol).
18. Derive TdS equations?
19. What is a refrigerator? Explain the working of a refrigerator? (Ceiling – 30)

SECTION C – Essay type

(Essays - Answer in about two pages, any one question. Answer carries 10 marks)

20. What are thermodynamic potential functions? Derive the expressions for thermodynamic potential functions?
21. (a) What is entropy? Write short note on its significance?
(b) Derive the expression for entropy of ideal gas. (1 · 10 = 10 marks)

MODEL QUESTION PAPER - 2

Name.....

Reg. No.....

SIXTH SEMESTER B.Sc. DEGREE EXAMINATION 20.....

(CBCSS-UG)

Core Course – Physics: PHY6B10 – THERMODYNAMICS

Time: 2 Hrs

Maximum: 60 Marks

The symbols used in this question paper have their usual meanings

Section A – Short Answer type.

(Answer all questions in two or three sentences, each correct answer carries a maximum of 2 marks)

1. State and explain Zeroth law of thermodynamics?
2. What is meant by quasi-static process?
3. What is entropy? Explain the entropy of reversible and irreversible processes?
4. State the Principle of increase of entropy?
5. State Kelvin-Planck and Clausius statement of Second law of thermodynamics?
6. Compare the slopes of adiabatic and isothermals?
7. What is latent heat?
8. Write short note on internal energy?
9. State and explain Carnot's theorem?
10. Distinguish between intensive and extensive properties of a thermodynamic system?
11. Draw the PV diagrams of thermodynamic processes?
12. State First law of thermodynamics? Write the differential form of First law?

(Ceiling – 20)

Section B – Paragraph / Problem type.

(Answer all questions in a paragraph of about half a page to one page, each correct answer carries a maximum of 5 marks)

13. Show that $C_p - C_v = R$.
14. Explain the working of a Carnot's engine and derive the expression for efficiency?
15. What is meant by phase transitions? Obtain the Clausius- Clayperon equation of phase transition?

16. Calculate the depression of melting point of ice by 1 atm increase of pressure, given latent heat of ice = $3.35 \times 10^5 \text{ J/Kg}$ and the specific volumes of 1 Kg of ice and water at 0°C are $1.090 \times 10^{-3} \text{ m}^3$ and 10^{-3} m^3 respectively.
17. Show that for a perfect gas $\left(\frac{\partial u}{\partial v}\right)_T = 0$.
18. A Carnot's engine whose lower temperature reservoir is at 7°C has an efficiency of 50%. It is desired to increase the efficiency to 70%. By how many degrees should the temperature of the high temperature reservoir be increased?
19. What is TS diagram? Discuss the TS diagram of isothermal and adiabatic processes? Find the efficiency of Carnot's engine using TS diagram? (Ceiling – 30)

SECTION C – Essay type

(Essays - Answer in about two pages, any one question. Answer carries 10 marks)

20. Derive the Maxwell's thermodynamic relations from thermodynamic potentials functions?
21. (a) What are isothermal and adiabatic processes?
 (b) Derive the equation for work done in isothermal and adiabatic processes?

(1 - 10 = 10 marks)

MODEL QUESTION PAPER - 1

Name.....

Reg. No.....

SIX SEMESTER B.Sc. DEGREE EXAMINATION 20.....
(CBCSS-UG)

Core Course – Physics: PHY6B11 – STATISTICAL PHYSICS, SOLID STATE PHYSICS,
SPECTROSCOPY AND PHOTONICS

Time: 2 Hrs

Maximum: 60 Marks

The symbols used in this question paper have their usual meanings

Section A – Short Answer type.

(Answer all questions in two or three sentences, each correct answer carries a maximum of 2 marks)

1. Distinguish between a microstate and a macrostate.
2. What are Bravais lattices? Give an example.
3. What is meant by unit cell? Give an example.
4. What is packing fraction?
5. Give the selection rules for rotational spectroscopy.
6. What is a symmetric top molecule? Give an example.
7. What is zero point energy of a harmonic oscillator?
8. Discuss the Born – Oppenheimer approximation.
9. What are hot bands?
10. What is pumping? Give two examples of pumping mechanisms.
11. List out some differences between laser light and ordinary light.
12. What is stimulated emission?

(Ceiling – 20)

Section B – Paragraph / Problem type.

(Answer all questions in a paragraph of about half a page to one page, each correct answer carries a maximum of 5 marks)

13. How does the Rayleigh – Jeans law fail to explain the black body spectrum?
14. Compare average velocity, root mean square velocity and most probable velocity
15. Explain the three types of cubic crystal systems and the coordination number of each
16. Explain the anharmonic vibration spectrum of a diatomic molecule

17. The bond length in HF molecule is 0.0927 nm. Calculate its rotational constant in cm^{-1} and also its moment of inertia
18. For X – ray diffraction from a Sodium Chloride crystal with lattice spacing 0.282 nm, the first order Bragg reflection is observed at an angle of $8^{\circ}35'$. Find the wavelength of X – rays and the glancing angle for third order Bragg reflection.
19. The fundamental band for HCl is centred at 2886 cm^{-1} . Find the wave number in cm^{-1} of the first lines in the P branch and R branch of the infrared spectrum. Take the internuclear distance to be 1.276 Angstrom. (Ceiling – 30)

SECTION C – Essay type

(Essays - Answer in about two pages, any one question. Answer carries 10 marks)

20. Derive the expression for molecular energy distribution of an ideal gas.
21. Explain the structure and working of Bragg's X – ray spectrometer. (1 · 10 = 10 marks)

MODEL QUESTION PAPER - 2

Name.....

Reg. No.....

SIXTH SEMESTER B.Sc. DEGREE EXAMINATION 20.....
(CBCSS-UG)

Core Course – Physics: PHY6B11 – STATISTICAL PHYSICS, SOLID STATE PHYSICS,
SPECTROSCOPY AND PHOTONICS

Time: 2 Hrs

Maximum: 60 Marks

The symbols used in this question paper have their usual meanings

Section A – Short Answer type.

(Answer all questions in two or three sentences, each correct answer carries a maximum of 2 marks)

1. Explain the term distribution function.
2. What are Bosons? Give two examples.
3. Explain the term crystal lattice and basis.
4. Explain Bragg's law.
5. What is meant by a spherical top molecule? Give an example.
6. What is isotopic substitution?
7. Give the selection rules for vibration spectroscopy.
8. What is Morse curve?
9. Explain the terms –(i) population inversion (ii) metastable state.
10. Give any two applications of lasers.
11. Explain any two types of pumping mechanism.
12. What are Stokes' lines and anti-Stokes' lines? (Ceiling – 20)

Section B – Paragraph / Problem type.

(Answer all questions in a paragraph of about half a page to one page, each correct answer carries a maximum of 5 marks)

13. Compare Maxwell – Boltzmann, Fermi-Dirac and Bose – Einstein statistics
14. Derive and explain Bragg's law
15. Explain the spectrum of a non – rigid rotator
16. Briefly explain the quantum theory of Raman scattering with a neat diagram
17. Find the energy in cm^{-1} of the photon absorbed when an NO molecule undergoes transition $v = 0, J' = 0$ state to $v = 1, J' = 1$ state where v is the vibrational quantum number and J is

the rotational quantum number. Assume that B is the same in both states. Given $\nu_e = 1.904 \text{ cm}^{-1}$ and $\chi_e = 0.00733$ and $r_{\text{NO}} = 0.1151 \text{ nm}$

18. The rotational and centrifugal constants of HCl molecule are 10.593 cm^{-1} and $5.3 \times 10^{-4} \text{ cm}^{-1}$. Find the vibrational frequency and the force constant of the molecule
19. Obtain the Miller indices of a plane with intercepts at a , $(b/2)$ and $3c$ in a simple cubic unit cell. (Ceiling – 30)

SECTION C – Essay type

(Essays – Answer in about two pages, any one question. Answer carries 10 marks)

20. Describe the theory of pure rotational spectrum of a rigid diatomic molecule
21. Explain, with necessary diagrams, the construction and working of a He-Ne Laser (1 · 10 = 10 marks)

MODEL QUESTION PAPER - 1

Name.....

Reg. No.....

SIXTH SEMESTER B.Sc. DEGREE EXAMINATION 20.....
(CBCSS-UG)

Core Course – Physics: PHY6B12 – NUCLEAR PHYSICS AND PARTICLE PHYSICS

Time: 2 Hrs

Maximum: 60 Marks

The symbols used in this question paper have their usual meanings

Section A – Short Answer type.

(Answer all questions in two or three sentences, each correct answer carries a maximum of 2 marks)

1. Why do heavy nuclei have more neutrons than protons?
2. Comment on the property of nuclear force.
3. Explain why a fusion reactor requires a high particle density, a high temperature and a long confinement time?
4. Write a short note on radio isotope production in nuclear reaction.
5. Which are the three requirements to increase the probability of collision between the ions that would result in fusion?
6. Explain the terms particle and antiparticle.
7. Write a short note on natural radio activity.
8. What do you mean by resonance particle?
9. What is the limitation of linear accelerator?
10. Draw neat diagram and Write essential part of Scintillation counter.
11. Write the theory Betatron.
12. What is the working principal of Ionization chamber? (Ceiling – 20)

Section B – Paragraph / Problem type.

(Answer all questions in a paragraph of about half a page to one page, each correct answer carries a maximum of 5 marks)

13. Write short note on Radioactive decay. The half life of ^{198}Au is 2.70 days (a) What is the decay constant of ^{198}Au (b) suppose we had a $1.00\ \mu\text{g}$ sample of ^{198}Au . What is its activity?
14. Write a short note on nuclear masses and binding energies?
15. Explain briefly the application of nuclear physics?
16. Discuss the Quark model?

17. Discuss briefly low energy reaction kinematics?

18. Discuss the working of Proton synchrotron?

19. Write the working of Photographic plate?

(Ceiling – 30)

SECTION C – Essay type

(Essays - Answer in about two pages, any one question. Answer carries 10 marks)

20. Using Neat diagram explain the working principle of van de Graaf electrostatic generator?

21. List the families of elementary particle? Discuss the conservation law in particle interaction? (1 · 10 = 10 marks)

MODEL QUESTION PAPER - 2

Name.....

Reg. No.....

SIXTH SEMESTER B.Sc. DEGREE EXAMINATION 20.....
(CBCSS-UG)

Core Course – Physics: PHY6B12 – NUCLEAR PHYSICS AND PARTICLE PHYSICS

Time: 2 Hrs

Maximum: 60 Marks

The symbols used in this question paper have their usual meanings

Section A – Short Answer type.

(Answer all questions in two or three sentences, each correct answer carries a maximum of 2 marks)

1. Why the nuclei are so small compared to the atom?
2. What is mean by binding energy of the atoms?
3. What are the applications of nuclear physics?
4. Mention any two conservation laws in radioactive decay?
5. In general, would you expect fission fragment to decay by positive or negative beta decay? Why?
6. List some similarities and difference between the properties of photons and neutrinos.
7. List the four families of elementary particles.
8. What do you mean by delayed neutrons?
9. What is mean by particle acceleration
10. Briefly given the working of Cosmotron.
11. What are the advantages of GM Counter?
12. What is the limitation of Bubble Chamber? (Ceiling – 20)

Section B – Paragraph / Problem type.

(Answer all questions in a paragraph of about half a page to one page, each correct answer carries a maximum of 5 marks)

13. Explain Beta and Gamma decay processes.
14. Explain “MOSSBAUER” Effect. Find the maximum kinetic energy of the electron emitted in the negative beta decay of ^{11}Be .
15. Distinguish between fission and fusion reactions. Explain the fusion process in stars?
16. Discuss briefly three different types of fission reactors.
17. Write a short note on elementary particle interactions and decays.

18. Discuss the working principle of Van de Graff electro statics generator.

19. Discuss the working of Ionization chamber.

(Ceiling – 30)

SECTION C – Essay type

(Essays - Answer in about two pages, any one question. Answer carries 10 marks)

20. Obtain an expression for the binding energy per nucleon of a nucleus using liquid drop model. Discuss the corrections to the expression from asymmetry energy and pairing energy and obtain the semi empirical binding energy formula.

21. Explain Radioisotope production in nuclear reactions. Discuss the main features of nuclear fusion reactors

(1 - 10 = 10 marks)

MODEL QUESTION PAPER - 1

Name.....

Reg. No.....

SIXTH SEMESTER B.Sc. DEGREE EXAMINATION 20.....
(CBCSS-UG)

Core Course – Physics: PHY6B13 – RELATIVISTIC MECHANICS AND ASTROPHYSICS
Time: 2 Hrs Maximum: 60 Marks

The symbols used in this question paper have their usual meanings

Section A – Short Answer type.

(Answer all questions in two or three sentences, each correct answer carries a maximum of 2 marks)

1. State the postulates of special relativity
2. What are Galilean transformations?
3. Explain length contraction.
4. What is the concept of simultaneity in relativistic mechanics?
5. Describe the relativistic Doppler Effect.
6. State and explain the principle of equivalence.
7. Explain the concept of dark matter.
8. What is meant by the Chandrasekhar limit?
9. Explain the terms (a) stellar parallax (b) luminosity.
10. Write on the internal structure of the Sun.
11. State and explain Hubble's law.
12. What are pulsars?

(Ceiling – 20)

Section B – Paragraph / Problem type.

(Answer all questions in a paragraph of about half a page to one page, each correct answer carries a maximum of 5 marks)

13. Obtain the relation for time dilation
14. Briefly describe the Hertzsprung – Russell diagram
15. Describe the classification of galaxies
16. An observer O is standing on a platform of length 65 m. A vehicle passes parallel to the platform at a speed of $0.8c$. The observer O sees the front and back ends of the vehicle coincide with the platform at a particular instant. Find (a) the rest length of the rocket (b) the time required for the vehicle to pass a point on the platform as measured by O.

17. A spaceship moving away from the earth at a speed of $0.8c$ fires a rocket along its direction of motion at a speed of $0.6c$ relative to itself. Find the speed of the rocket relative to the earth. Compare the answer with the classical result.
18. Find the velocity and momentum of an electron of kinetic energy 10 MeV .
19. Obtain the relation between absolute magnitude and apparent magnitude. (Ceiling – 30)

SECTION C – Essay type

(Essays - Answer in about two pages, any one question. Answer carries 10 marks)

20. Obtain the Lorentz transformation equations.
21. Describe the various mechanisms possible in the death of star. (1 · 10 = 10 marks)

MODEL QUESTION PAPER - 2

Name.....

Reg. No.....

SIXTH SEMESTER B.Sc. DEGREE EXAMINATION 20.....

(CBCSS-UG)

Core Course – Physics: PHY6B13 – RELATIVISTIC MECHANICS AND ASTROPHYSICS
Time: 2 Hrs Maximum: 60 Marks

The symbols used in this question paper have their usual meanings

Section A – Short Answer type.

(Answer all questions in two or three sentences, each correct answer carries a maximum of 2 marks)

1. Write down and explain the Lorentz transformation equations.
2. What is time dilation?
3. Explain relativistic addition of velocities.
4. Why the speed of light is considered the ultimate speed?
5. Explain the variation of mass with velocity.
6. Write down two experimental tests of the general theory of relativity.
7. What are neutron stars?
8. What is meant by Cosmic Microwave Background Radiation?
9. Explain the terms (a) apparent magnitude (b) absolute magnitude.
10. Write on the proton – proton chain reaction.
11. What is the relation between stellar parallax and distance?
12. Describe gravitational lensing. (Ceiling – 20)

Section B – Paragraph / Problem type.

(Answer all questions in a paragraph of about half a page to one page, each correct answer carries a maximum of 5 marks)

13. Obtain Einstein's mass energy relation.
14. Briefly describe (a) globular clusters (b) planetary nebulae.
15. Describe Cepheid variables and their period – luminosity relation.
16. Explain the twin paradox.
17. The proper lifetime of a particle is 10 ns. How long does it live in laboratory if it moves at a speed of 0.960c. How far does it travel before decaying?

18. A neutral K meson at rest decays into two particles that travel in opposite directions with speed $0.828c$. If instead the K meson was travelling at a speed of $0.486c$ while decaying, what would be the velocities of the two particles?
19. Obtain the relation between relativistic momentum and energy. (Ceiling – 30)

SECTION C – Essay type

(Essays - Answer in about two pages, any one question. Answer carries 10 marks)

20. Describe the Michelson – Morley experiment. How does it invalidate the concept of ether?
21. Describe the main features of the Hertzprung – Russell diagram. (1 · 10 = 10 marks)

MODEL QUESTION PAPER - 1

Name.....

Reg. No.....

SIXTH SEMESTER B.Sc. DEGREE EXAMINATION 20.....
(CBCSS-UG)

Core Course – Physics: PHY6B014 (EL1) – BIOMEDICAL PHYSICS

Time: 2 Hrs

Maximum: 60 Marks

The symbols used in this question paper have their usual meanings

Section A – Short Answer type.

(Answer all questions in two or three sentences, each correct answer carries a maximum of 2 marks)

1. Give the essential principles of X-ray fluoroscopy.
2. Explain the concept of Donnan equilibrium.
3. What are the different signals generated in EEG?
4. Outline any two static characteristics of a transducer.
5. What is a biosensor?
6. Enumerate different valve systems of a human cardio.
7. What are the modes of transmission of ultrasound?
8. Explain the term "action potential".
9. What is the role of X-ray in angiography?
10. Distinguish between A-scan and B-scan in ultrasound imaging.
11. What is a "gamma camera"?
12. What are the important lasers used in Dermatology? (Ceiling – 20)

Section B – Paragraph / Problem type.

(Answer all questions in a paragraph of about half a page to one page, each correct answer carries a maximum of 5 marks)

13. What are the biological effects of NMR imaging?
14. When food enters the stomach, it stimulates the production and secretion of hydrochloric acid for digestion, reducing the stomach pH from 4 to 2. What is the concentration of the acid (assuming all the pH is due to HCl) before and after the change in pH?
15. Give a note on Helical CT Scanner.
16. Explain Hodgkin-Huxley model for membrane transport in human body.

17. How Laser emission is made possible in a CO₂ laser?
18. Explain the operating principle of EMG.
19. What is the principle of Positron Emission Tomography? (Ceiling – 30)

SECTION C – Essay type

(Essays - Answer in about two pages, any one question. Answer carries 10 marks)

20. Give a brief account about the various fluid transport processes taking place in human body cells.
21. What is the basic principle of NMR imaging? What are gradient coils? Briefly explain the different components used in a NMR imaging system? (1 · 10 = 10 marks)

MODEL QUESTION PAPER - 2

Name.....

Reg. No.....

SIXTH SEMESTER B.Sc. DEGREE EXAMINATION 20.....
(CBCSS-UG)

Core Course – Physics: PHY6B014 (EL1) – BIOMEDICAL PHYSICS

Time: 2 Hrs

Maximum: 60 Marks

The symbols used in this question paper have their usual meanings

Section A – Short Answer type.

(Answer all questions in two or three sentences, each correct answer carries a maximum of 2 marks)

1. What is Brownian motion?
2. The Reynolds number for a bacterium is 10^{11} smaller than that of a human. Comment on the relative importance of the inertial and viscous forces based on this information.
3. How is a nerve impulse or action potential generated?
4. What are transducers? How are they classified?
5. State any two bioelectric signals with primary signal characteristics referring to their frequency range and typical signal amplitude.
6. What are biomedical signals? List any four sources of them.
7. What is the principle of a CT scan?
8. What are tracers in diagnostic applications?
9. List the basic NMR components.
10. How does Laser light differ from ordinary light with respect to coherence?
11. State any four potential advantages of laser surgery.
12. What are ultrasonic waves? (Ceiling – 20)

Section B – Paragraph / Problem type.

(Answer all questions in a paragraph of about half a page to one page, each correct answer carries a maximum of 5 marks)

13. What are the biological effects of NMR imaging?
14. What are the advantages of Computer tomography with respect to conventional X-rays?
15. Discuss the advantages of a MRI system with respect to a CT imaging.
16. Write a short note on Nd:YAG laser.

17. What is the Reynolds number for blood flowing through an artery 10^{-3} m in diameter, assuming that the density and dynamical viscosity of blood are comparable from the corresponding values of water. Assume that the speed of blood is roughly 0.1ms^{-1} . The density of water is 10^3kgm^{-3} and dynamical viscosity 10^{-3}Nsm^{-2} .
18. What is resting potential? Obtain Einstein equation relating mobility to the diffusion constant.
19. Write a short note on Generation of ultrasound. Discuss the biological effects of ultrasound. (Ceiling – 30)

SECTION C – Essay type

(Essays - Answer in about two pages, any one question. Answer carries 10 marks)

20. Discuss the transport of substances through the cell membrane with reference to the following:
i) Diffusion and ii) Viscosity.
21. Explain the principles of NMR imaging systems. What are the biological effects of NMR imaging? (1 · 10 = 10 marks)

MODEL QUESTION PAPER - 1

Name.....

Reg. No.....

SIXTH SEMESTER B.Sc. DEGREE EXAMINATION 20.....
(CBCSS-UG)

Core Course – Physics: PHY6B014 (EL2) – NANOSCIENCE AND TECHNOLOGY

Time: 2 Hrs

Maximum: 60 Marks

The symbols used in this question paper have their usual meanings

Section A – Short Answer type.

(Answer all questions in two or three sentences, each correct answer carries a maximum of 2 marks)

1. Draw the band structure of an insulator indicating valence band, conduction band and energy gap.
2. Write down Heisenberg's uncertainty principle.
3. Write the Schrodinger equation of particle in a box.
4. Show a graph illustrating the variation of Fermi-Dirac function with temperature.
5. Explain Arrhenius type conductivity.
6. What is Schottky effect?
7. Write a short note on variable range hopping conduction.
8. What is meant by an exciton?
9. List the names of any four solution based techniques for nanomaterials synthesis.
10. Explain Lithographic and non lithographic processes?
11. Write merits and demerits of Ball milling process in growth techniques of Nanotechnology.
12. Discuss the structure of Boron Nitride nanotubes. (Ceiling – 20)

Section B – Paragraph / Problem type.

(Answer all questions in a paragraph of about half a page to one page, each correct answer carries a maximum of 5 marks)

13. Draw and explain the schematic diagram of the splitting of energy levels isolated atoms into energy bands.
14. Discuss the conduction mechanism in ionic crystals..
15. Write a short on the energy quantization in a nano-film. Give an example.

16. Draw the schematic diagram of electron beam evaporator system and indicate the parts.
17. Explain the charge transfer in STM in terms of local density of states.
18. A beam of 12 eV electrons is incident on a potential barrier of height 30eV and width 0.05 nm. Calculate the transmission co-efficient.
19. A gold sphere of radius 2cm is converted into spherical nanoparticles of diameter 2nm, without any loss in volume. Find a) The number of gold nanoparticles b) the ratio of surface area of all the nanospheres to that of the original sphere. (Ceiling – 30)

SECTION C – Essay type

(Essays - Answer in about two pages, any one question. Answer carries 10 marks)

20. Explain the Drude model of electrical conduction in metals. Obtain an expression for the DC electrical conductivity.
21. Derive an expression for the wave function of a particle confined in 1 D infinite potential well. Draw the corresponding energy distribution. (1 · 10 = 10 marks)

MODEL QUESTION PAPER - 2

Name.....

Reg. No.....

SIXTH SEMESTER B.Sc. DEGREE EXAMINATION 20.....
(CBCSS-UG)

Core Course – Physics: PHY6B014 (EL2) – NANOSCIENCE AND TECHNOLOGY

Time: 2 Hrs

Maximum: 60 Marks

The symbols used in this question paper have their usual meanings

Section A – Short Answer type.

(Answer all questions in two or three sentences, each correct answer carries a maximum of 2 marks)

1. Distinguish between intrinsic and extrinsic semiconductors.
2. Define density of states. Draw the density of states diagram of a 2-d nanostructure
3. What is field enhanced thermionic emission?
4. Name four allotropes of carbon.
5. Name the interactions that are monitored in a) STM b) AFM
6. Write down Schrödinger's 3D steady state equation and explain the symbols.
7. What is the effect of size on thermal time constant in the nano regime?
8. Explain conduction process in ionic crystals.
9. What are auger electrons?
10. Write the concept of Chemical Vapor Deposition?
11. Mention the advantages and disadvantages of solution based synthesis procedures of nanomaterials.
12. Discuss the structure of Buckminster fullerene. (Ceiling – 20)

Section B – Paragraph / Problem type.

(Answer all questions in a paragraph of about half a page to one page, each correct answer carries a maximum of 5 marks)

13. Describe an n-type semiconductor. Draw the energy band diagram of n-type semiconductor showing Fermi level and Donor level.
14. Discuss the Richardson-Dushman equation for thermionic emission.
15. Discuss the different structures of carbon nanotubes.
16. Describe a sputter deposition system.

17. Discuss the operating principle of AFM.
18. At what temperature will the number of conduction electrons increase by a factor 20 over room temperature for Ge? Given band gap is 0.67 eV.
19. The resistivity of an intrinsic semiconductor is $4.6 \text{ } \Omega\text{-m}$ at 20°C and $2 \text{ } \Omega\text{-m}$ at 32°C . What is the energy bandgap ? (Ceiling – 30)

SECTION C – Essay type

(Essays - Answer in about two pages, any one question. Answer carries 10 marks)

20. Describe Bohr's model of the hydrogen atom and derive the expression for energy of the n^{th} level. Explain how the line spectra of hydrogen atom are obtained.
21. Discuss the working principle of STM. Explain the factors influencing the STM image. (1 · 10 = 10 marks)

MODEL QUESTION PAPER - 1

Name.....

Reg. No.....

SIXTH SEMESTER B.Sc. DEGREE EXAMINATION, 20.....

(CBCSS-UG)

Core Course – Physics: PHY6B014 (EL3) – MATERIALS SCIENCE

Time: 2 Hrs

Maximum: 60 Marks

The symbols used in this question paper have their usual meanings

Section A – Short Answer type.

(Answer all questions in two or three sentences, each correct answer carries a maximum of 2 marks)

1. What do you mean by a point defect? Give Example.
2. Write down Fick's first law of diffusion and explain the terms involved
3. Explain Polymorphism?
4. What are amorphous solids?.
5. Distinguish between homo polymers and copolymers?
6. What is abrasive ceramics?
7. What are Secondary electrons?
8. What are nano materials ?
9. Distinguish between Hexagonal close packing and cubic close packing
10. What is isomerism in polymers
11. What are refractories?
12. Explain Metallic bonding in crystals. (Ceiling – 20)

Section B – Paragraph / Problem type.

(Answer all questions in a paragraph of about half a page to one page, each correct answer carries a maximum of 5 marks)

13. What are composites? Explain its properties.
14. Distinguish between vacancy diffusion and interstitial diffusion.
15. Explain Hydrogen bonding in water.
16. How will you determine grain size of a sample?
17. Distinguish between Frenkel and Schottky defects in solids.
18. Explain the principle of X-ray powder diffraction method of structural analysis.

19. Find out the packing fraction of FCC.

(Ceiling – 30)

SECTION C – Essay type

(Essays - Answer in about two pages, any one question. Answer carries 10 marks)

20. Describe the defects in Solids.

21. Explain the formation of bonds in solids.

(1 · 10 = 10 marks)

MODEL QUESTION PAPER - 2

Name.....

Reg. No.....

SIXTH SEMESTER B.Sc. DEGREE EXAMINATION 20.....

(CBCSS-UG)

Core Course – Physics: PHY6B014 (EL3) – MATERIALS SCIENCE

Time: 2 Hrs

Maximum: 60 Marks

The symbols used in this question paper have their usual meanings

Section A – Short Answer type.

(Answer all questions in two or three sentences, each correct answer carries a maximum of 2 marks)

1. How nanomaterials are made?
2. Explain Ionic bonding
3. Explain hydrogen bonding in water
4. What is meant by (a) Lattice (b) Unit cell?
5. Explain Grain and Grain boundary
6. Find the number of atoms in a FCC unit cell.
7. What are Allotropes? Give one Example
8. What are the two types of diffusion in solids?
9. What is glass ceramics? What are the properties?
10. What is isomerism in polymers with suitable example
11. What is mean by functionality of a monomer?
12. What is Burger's vector?

(Ceiling – 20)

Section B – Paragraph / Problem type.

(Answer all questions in a paragraph of about half a page to one page, each correct answer carries a maximum of 5 marks)

13. Find the atomic packing factor of Hexagonal unit cell.
14. Explain the Vander waals bonding?
15. Distinguish between vacancies and self interstitials.
16. Explain the factors effecting diffusion?
17. What is stress-strain behavior of ceramics?
18. Explain viscoelastic deformation of polymers.

19. Write a short note on Electron microscopy.

(Ceiling – 30)

SECTION C – Essay type

(Essays - Answer in about two pages, any one question. Answer carries 10 marks)

20. State and explain Bragg's law? Explain the working of Laue's Technique and rotating crystal method.

21. Explain the diffusion mechanism in solids.

(1 × 10 = 10 marks)

**Physics Open Courses
SEMESTER 5**

MODEL QUESTION PAPER - 1

Name.....

Reg. No.....

FIFTH SEMESTER B.Sc. DEGREE EXAMINATION 20.....
(CBCSS-UG)

Open Course – Physics: PHY5D01(1) - **NON CONVENTIONAL ENERGY SOURCES**

Time: 2 Hrs

Maximum: 60 Marks

The symbols used in this question paper have their usual meanings

Section A – Short Answer type.

(Answer all questions in two or three sentences, each correct answer carries a maximum of 2 marks)

1. Define solar constant.
2. What is the working principle of a pyranometer?
3. Explain the principle behind the working of a solar cooker.
4. What is the use of a solar green house?
5. What are the factors that determine the output from a wind energy converter?
6. Write any four disadvantages of wind energy.
7. What are the basic components of a tidal power plant?
8. List any two advantages of geothermal energy.
9. What do you mean by biomass?
10. Give one example each for a primary and a secondary battery.
11. What do you mean by energy efficiency of a battery?
12. Write four applications of a fuel cell. (Ceiling – 20)

Section B – Paragraph / Problem type.

(Answer all questions in a paragraph of about half a page to one page, each correct answer carries a maximum of 5 marks)

13. Discuss the working principle of a solar furnace.
14. What do you mean by photovoltaic effect? List three advantages of photovoltaic power conversion system.
15. Discuss the applications of wind energy.
16. Explain the term biomass conversion. Discuss the different biomass conversion technologies.
17. What is meant by a hydrothermal source? Discuss the different hydrothermal sources.

18. What is the origin of source of energy in waves? Discuss a method for converting wave energy into mechanical energy.

19. Discuss the source of geothermal energy. (Ceiling – 30)

SECTION C – Essay type

(Essays - Answer in about two pages, any one question. Answer carries 10 marks)

20. Discuss the working principle of a solar water heater with help of a schematic diagram.

What are the merits of a solar water heater over a conventional water heater?

21. What is the principle of wind energy conversion? With the help of a block diagram, discuss the basic components of a wind energy conversion system. List a few advantages of wind energy conversion system. (1 · 10 = 10 marks)

MODEL QUESTION PAPER - 2

Name.....

Reg. No.....

FIFTH SEMESTER B.Sc. DEGREE EXAMINATION 20.....

(CBCSS-UG)

Open Course – Physics: PHY5D01(1) - **NON CONVENTIONAL ENERGY SOURCES**

Time: 2 Hrs

Maximum: 60 Marks

The symbols used in this question paper have their usual meanings

Section A – Short Answer type.

(Answer all questions in two or three sentences, each correct answer carries a maximum of 2 marks)

1. Distinguish between direct and diffuse components of solar radiation.
2. What are the instruments used for measuring solar radiation and sun shine?
3. List four merits of a solar cooker.
4. List any four advantages of a solar furnace.
5. What are the causes for local winds?
6. Give four advantages of wind energy utilization.
7. What are the four sources of energy available from oceans?
8. What are the essential parts of a tidal power plant?
9. What are the environmental benefits of use of biomass?
10. What is an electrochemical cell?
11. What are the main uses of a storage battery?
12. Write down the problems associated with storage of hydrogen fuel in motor vehicles.

(Ceiling – 20)

Section B – Paragraph / Problem type.

(Answer all questions in a paragraph of about half a page to one page, each correct answer carries a maximum of 5 marks)

13. Explain the working principle of a solar distillation system, using a neat diagram.
14. What are the essential parts of a photovoltaic system? What are the basic processes involved in a solar cell.
15. Draw the schematic diagram of a horizontal axis wind mill indicating the essential parts.
16. Write briefly about liquid and gaseous biofuels.

17. Write briefly on geothermal sources of energy.
18. List any four limitations of tidal power generation.
19. List the advantages and disadvantages of a fuel cell.

(Ceiling – 30)

SECTION C – Essay type

(Essays - Answer in about two pages, any one question. Answer carries 10 marks)

20. Discuss the fundamental processes used in the conversion of solar radiation to heat energy. Using a suitable schematic diagram, discuss the essential parts of a flat plate collector.
21. Discuss the principle of ocean thermal energy conversion (OTEC). Discuss the open cycle and closed cycle methods of ocean thermal electric power conversion. (1 · 10 = 10 marks)

MODEL QUESTION PAPER - 1

Name.....

Reg. No.....

FIFTH SEMESTER B.Sc. DEGREE EXAMINATION 20.....
(CBCSS-UG)

Open Course – Physics: PHY5D01(2) - **AMATEUR ASTRONOMY AND ASTROPHYSICS**
Time: 2 Hrs Maximum: 60 Marks

The symbols used in this question paper have their usual meanings

Section A – Short Answer type.

(Answer all questions in two or three sentences, each correct answer carries a maximum of 2 marks)

1. Explain longitude and latitude.
2. What is meant by perihelion?
3. What is Kuiper belt?
4. Define the astronomical unit of distance.
5. What is meant by equinox?
6. State and explain Hubble's law.
7. What is Cosmic Microwave Background Radiation?
8. Describe neutron stars.
9. What are the advantages of reflecting telescopes?
10. Describe the formation of seasons on Earth.
11. What is meant by supernova?
12. Discuss the main features of the planet Jupiter. (Ceiling – 20)

Section B – Paragraph / Problem type.

(Answer all questions in a paragraph of about half a page to one page, each correct answer carries a maximum of 5 marks)

13. Differentiate between solar and lunar eclipses.
14. Explain the proton – proton chain reaction.
15. Briefly explain (a) white dwarf (b) comet.
16. Explain the parallax method of distance measurement.
17. Explain the important regions of the HR diagram.
18. Derive the relation between absolute luminosity and apparent luminosity.
19. Discuss elliptical and spiral galaxies. (Ceiling – 30)

SECTION C – Essay type

(Essays - Answer in about two pages, any one question. Answer carries 10 marks)

20. Describe in detail the structure of the sun.

21. Describe the theory of planetary formation in the solar system. (1 · 10 = 10 marks)

MODEL QUESTION PAPER - 2

Name.....

Reg. No.....

**FOURTH SEMESTER B.Sc. DEGREE EXAMINATION 20.....
(CBCSS-UG)**

Open Course – Physics: PHY5D01(2) - **AMATEUR ASTRONOMY AND ASTROPHYSICS**
Time: 2 Hrs Maximum: 60 Marks

The symbols used in this question paper have their usual meanings

Section A – Short Answer type.

(Answer all questions in two or three sentences, each correct answer carries a maximum of 2 marks)

1. Explain the term solstice
2. What is meant by perigee and apogee?
3. What is Asteroid belt?
4. Define and explain absolute luminosity of a star
5. What are Cepheid variables?
6. Explain quasars
7. Compare astronomy and astrology
8. What is meant by the term black hole?
9. What are the different types of telescopes?
10. Describe the corona of the sun
11. What is meant by solar flare?
12. Discuss the main features of the planet Saturn.

(Ceiling – 20)

Section B – Paragraph / Problem type.

(Answer all questions in a paragraph of about half a page to one page, each correct answer carries a maximum of 5 marks)

13. Explain Chandrasekhar limit
14. What is the main energy production mechanism in stars?
15. Briefly explain (a) photosphere (b) chromospheres
16. Explain how the scientific method is applied in Astronomy
17. Describe the main features of the Big Bang theory

18. Derive the Pogson's relation

19. Discuss the classification of galaxies.

(Ceiling – 30)

SECTION C – Essay type

(Essays - Answer in about two pages, any one question. Answer carries 10 marks)

20. Describe the Harvard classification scheme of stars

21. Explain the Hertzsprung – Russell diagram and describe its major regions

(1 · 10 = 10 marks)

MODEL QUESTION PAPER - 1

Name.....

Reg. No.....

FOURTH SEMESTER B.Sc. DEGREE EXAMINATION 20.....
(CBCSS-UG)

Open Course – Physics: PHY5D01(3) - ELEMENTARY MEDICAL PHYSICS

Time: 2 Hrs

Maximum: 60 Marks

The symbols used in this question paper have their usual meanings

Section A – Short Answer type.

(Answer all questions in two or three sentences, each correct answer carries a maximum of 2 marks)

1. What is an electromyograph.
2. Write the value of Planck's constant.
3. What are ions?
4. Give an example of non-ionizing radiation.
5. What is REM/
6. What are evoked potentials?
7. What is 'CT' in medical imaging .
8. What are tracers in diagnostic applications?
9. What is radioactivity?
10. Who discovered X-rays.
11. What is the unit of frequency of sound waves?
12. What are ultrasonic waves?

(Ceiling – 20)

Section B – Paragraph / Problem type.

(Answer all questions in a paragraph of about half a page to one page, each correct answer carries a maximum of 5 marks)

13. What are biomedical signals? List any four sources of them.
14. Compare photoelectric effect and Compton Effect.
15. What is piezoelectric effect?
16. Write a note on conventional sources of radiation.
17. Discuss cardiac cycle and arrhythmias.
18. Discuss the units of radiations. What is radiation protection?

19. Write the properties of X-ray. What is X-ray attenuation in imaging? (Ceiling – 30)

SECTION C – Essay type

(Essays - Answer in about two pages, any one question. Answer carries 10 marks)

20. Write a short note on nuclear medicines..

21. Discuss the generation and detection of ultrasound. (1 · 10 = 10 marks)

MODEL QUESTION PAPER - 2

Name.....

Reg. No.....

FOURTH SEMESTER B.Sc. DEGREE EXAMINATION 20.....
(CBCSS-UG)

Open Course – Physics: PHY5D01(3) - ELEMENTARY MEDICAL PHYSICS

Time: 2 Hrs

Maximum: 60 Marks

The symbols used in this question paper have their usual meanings

Section A – Short Answer type.

(Answer all questions in two or three sentences, each correct answer carries a maximum of 2 marks)

1. State the three forms of radioactive emissions.
2. Define the curie.
3. What is Photo-electric effect?
4. What is Compton Scattering?
5. What is an electroencephalogram (EEG).
6. What is an electromyogram (EMG)?
7. What is 'bradycardia'?
8. What are X-rays?
9. What are ultrasonic waves?
10. What is Planck's constant?
11. What is the difference between an atom and an ion?
12. What is PET?

(Ceiling – 20)

Section B – Paragraph / Problem type.

(Answer all questions in a paragraph of about half a page to one page, each correct answer carries a maximum of 5 marks)

13. Describe a cardiac cycle.
14. Explain the term 'the blood pressure is 120/80 mm Hg'.
15. How are X-rays produced?
16. What is fluoroscopy?
17. Discuss the artifacts on the ECG trace.
18. Write a summary of the history of medical imaging.
19. Discuss X-ray attenuation in X-ray imaging.

(Ceiling – 30)

SECTION C – Essay type

(Essays - Answer in about two pages, any one question. Answer carries 10 marks)

20. Write a short note on Generation of ultrasound. Discuss the biological effects of ultrasound.

21. What is ionizing and non-ionizing radiations? Write a short note on non-ionizing radiation.

(1 · 10 = 10 marks)

**B. Sc Physics Complementary
SEMESTER 1 & 2**

MODEL QUESTION PAPER 1

Name.....

Reg. No.....

FIRST SEMESTER B.Sc. DEGREE EXAMINATION 20.....
(CBCSS-UG)

Complementary Course – Physics: PHY1C01- PROPERTIES OF MATTER &
THERMODYNAMICS

Time: 2 Hrs

Maximum: 60 Marks

The symbols used in this question paper have their usual meanings

Section A – Short Answer type.

(Answer all questions in two or three sentences, each correct answer carries a maximum of 2 marks)

1. What is a cantilever?
2. What is 'angle of twist' and 'angle of shear'?
3. Define Brownian motion. Explain the effect of temperature.
4. How does the pressure affect the boiling point of water and melting point of ice?
5. State and explain first law of thermodynamics
6. Define surface tension. Give its dimension
7. Write down *Clausius-Clapyron* equation
8. What do you meant by quasi static process?
9. State *Carnot* theorem.
10. Distinguish between isothermal and adiabatic process
11. Explain why $C_P > C_V$
12. State and explain the principle of increase of entropy (Ceiling – 20)

Section B – Paragraph / Problem type.

(Answer all questions in a paragraph of about half a page to one page, each correct answer carries a maximum of 5 marks)

13. Derive the expression for excess pressure inside a liquid bubble?
14. Obtain the relation between various elastic constants
15. Derive the expression for work done during adiabatic process
16. What do you meant by entropy? Show that the entropy remains constant in reversible process but increases in irreversible process

17. Calculate the work done in twisting a steel wire of radius 10^{-3} m. and length 0.25 m. through an angle 45° . Given the rigidity modulus of the wire is $8 \times 10^{10} \text{ Nm}^{-2}$.
18. Calculate the amount of energy evolved when 8 droplets of water of surface tension 0.072 N/m and radius 0.5 mm each combine to one.
19. A Carnot engine works between two temperatures whose difference is 100°C . If it absorbs 746 J of heat from source and gives 546 J to sink, calculate the temperature of source and sink. (Ceiling – 30)

SECTION C – Essay type

(Essays - Answer in about two pages, any one question. Answer carries 10 marks)

20. What is torsional pendulum? Derive expression for its time period. Using the pendulum how will you determine the rigidity modulus of wire?
21. Describe the working of a Carnot's engine. Define efficiency of a heat engine. Derive an expression for efficiency of a Carnot engine. (1 × 10 = 10 marks)

MODEL QUESTION PAPER 2

Name.....

Reg. No.....

FIRST SEMESTER B.Sc. DEGREE EXAMINATION, 20.....

(CBCSS-UG)

**Complementary Course – Physics: PHY1C01- PROPERTIES OF MATTER &
THERMODYNAMICS**

Time: 2 Hrs

Maximum: 60 Marks

The symbols used in this question paper have their usual meanings

Section A – Short Answer type.

(Answer all questions in two or three sentences, each correct answer carries a maximum of 2 marks)

1. What is torsional rigidity of a wire.
2. What is viscosity? Give its dimension.
3. What is Poise?
4. How does the temperature and pressure affect viscosity of a liquid?
5. Explain why liquids possess surface tension.
6. Define rigidity modulus. Write down the relation connecting three moduli of elasticity.
7. State and explain zero'th law of thermodynamics.
8. Define *carnot* theorem.
9. Draw P-V diagram for Carnot cycle.
10. What are intensive and extensive properties?
11. State thermodynamic process.
12. What is entropy? (Ceiling – 20)

Section B – Paragraph / Problem type.

(Answer all questions in a paragraph of about half a page to one page, each correct answer carries a maximum of 5 marks)

13. Derive the expression for the work done in blowing a bubble.
14. Show that a hollow shaft of the same length, mass and material is stronger than a solid shaft.
15. Discuss the various factors which control surface tension of a liquid.
16. Use Maxwell's equation to obtain $C_p - C_v = R$.
17. What is an I-section girder? Why I-section girders are preferred?

18. Calculate the work done if one mole of an ideal gas is compressed very slowly at 27°C . to one fourth of the original volume. $R = 8.314 \text{ J.mol}^{-1} \text{ K}^{-1}$.
19. Find the efficiency of Carnot engine working between 127°C and 27°C . If it absorbs 840J of heat from the source, calculate the amount of heat rejected to the sink. (Ceiling – 30)

SECTION C – Essay type

(Essays - Answer in about two pages, any one question. Answer carries 10 marks)

20. Derive Poiseuille's formula for the flow of a liquid through a capillary tube. Mention its limitations.
21. What is Carnot's engine? Derive an expression for its efficiency in terms of temperature of source and Sink. ($1 \times 10 = 10$ marks)

MODEL QUESTION PAPER 1

Name.....

Reg. No.....

SECOND SEMESTER B.Sc. DEGREE EXAMINATION, 20.....

(CBCSS-UG)

Complementary Course – Physics: PHY2C02-OPTICS, LASER & ELECTRONICS

Time: 2 Hrs

Maximum: 60 Marks

The symbols used in this question paper have their usual meanings

Section A – Short Answer type.

(Answer all questions in two or three sentences, each correct answer carries a maximum of 2 marks)

1. State superposition principle of waves.
2. Distinguish between Fresnel and Fraunhofer diffraction.
3. What are filter circuit.
4. What is meant by spontaneous emission and stimulated emission.
5. State De-Morgans theorem
6. What is meant by feedback circuit
7. Draw the input characteristics graph of CE configuration
8. Explain interference on thin film
9. What is meant by resolving power of a grating
10. How does Zener diode works as a voltage regulator
11. Explain the working of a π filter circuit.
12. What are half wave plates?

(Ceiling – 20)

Section B – Paragraph / Problem type.

(Answer all questions in a paragraph of about half a page to one page, each correct answer carries a maximum of 5 marks)

13. Write a note on constructive interference
14. Explain the principle and working of Ruby LASER
15. State and explain Brewster's law

16. What is meant by circularly polarized light
17. Obtain the relation between current amplification factors α, β and Y
18. A parallel beam of sodium light is incident normally on a plane transmission grating having 6×10^5 lines per meter length. The first order spectrum is found to be deviated through an angle of 20.7° from the normal. Calculate the wavelength of light used.
19. A transistor amplifier is biased with feedback resistor R_b of $100\text{k}\Omega$. If $V_{cc} = 20\text{V}$, $R_c = 1\text{k}\Omega$, $\beta = 100$ determine the operating points. (Ceiling – 30)

SECTION C – Essay type

(Essays - Answer in about two pages, any one question. Answer carries 10 marks)

20. Explain the theory of Newton's rings, explain how do we find wavelength of light using Newton's rings experiment
21. Explain the working of half wave rectifier. Obtain an expression for its efficiency and ripple factor. (1 · 10 = 10 marks)

MODEL QUESTION PAPER 2

Name.....

Reg No.....

SECOND SEMESTER B.Sc. DEGREE EXAMINATION 20.....

(CBCSS-UG)

Complementary Course – Physics: PHY2C02-OPTICS, LASER & ELECTRONICS

Time: 2 Hrs

Maximum: 60 Marks

The symbols used in this question paper have their usual meanings

Section A – Short Answer type.

(Answer all questions in two or three sentences, each correct answer carries a maximum of 2 marks)

1. State superposition principle of waves
2. What is meant by double refraction
3. Explain the reverse characteristics of a zener diode
4. What is meant by population inversion
5. Draw the symbol, Boolean algebra and truth table of Exclusive OR gate
6. Explain about capacitor filter circuit
7. What is an LC oscillator
8. Explain Fresnel's two mirror arrangement for producing interference
9. What are quarter wave plates
10. Distinguish between Fresnel and Fraunhofer diffraction
11. What do you mean by positive and negative feedback
12. What is meant by optical activity? (Ceiling – 20)

Section B – Paragraph / Problem type.

(Answer all questions in a paragraph of about half a page to one page, each correct answer carries a maximum of 5 marks)

13. Write a note on destructive interference
14. Explain the principle and working of a He-Ne Laser.
15. What are positive and negative crystals

- 16.** What is meant by elliptically polarized light
- 17.** Explain the working of a bridge rectifier
- 18.** In a Newton's rings experiment the diameter of the 15th ring was found to be 0.59cm and that of the 5th ring was 0.336 cm. If the radius of the Plano-convex lens is 100 cm, calculate the wave length of the light used.
- 19.** A full wave bridge rectifier is connected to a 12V step down transformer. If the forward resistance of each diode is 4Ω and load resistance is 400Ω , find the dc load current and efficiency of the rectifier. (Ceiling – 30)

SECTION C – Essay type

(Essays - Answer in about two pages, any one question. Answer carries 10 marks)

- 20.** Explain the theory of diffraction Grating. Discuss the experiment to find the wavelength of light using Grating experiment.
- 21.** Explain the working of a CE amplifier. Explain its frequency response (1 · 10 = 10 marks)

**B. Sc Physics Complementary
SEMESTER 3 & 4**

MODEL QUESTION PAPER 1

Name.....

Reg. No.....

THIRD SEMESTER B.Sc. DEGREE EXAMINATION 20..... (CBCSS-UG)

Complementary Course – Physics: PHY3C03-MECHANICS, RELATIVITY, WAVES AND
OSCILLATIONS

Time: 2 Hrs

Maximum: 60 Marks

The symbols used in this question paper have their usual meanings

Section A – Short Answer type.

(Answer all questions in two or three sentences, each correct answer carries a maximum of 2 marks)

1. State the theorem by which you can explain different quality of sound produced by different musical instruments.
2. What happens to the amplitude as time increases during damping?
3. What is Twin Paradox?
4. Explain the difference between inertial frame and non inertial frame.
5. Explain the significance of mass energy relation.
6. What is an anharmonic oscillator?
7. What is a centre of mass reference? Is it an inertial frame or non inertial frame of reference?
8. Define Coriolis force.
9. What is meant by length contraction?
10. Comment on 'Moving clock runs slow.'
11. Give two limitations of classical mechanics.
12. What do you mean by energy density? (Ceiling – 20)

Section B – Paragraph / Problem type.

(Answer all questions in a paragraph of about half a page to one page, each correct answer carries a maximum of 5 marks)

13. Derive the Galilean transformation equation and explain its invariance.

14. What is a central force? Show that central forces are conservative.
15. What are eigen values and eigen functions? Illustrate with examples.
16. State the law of conservation of angular momentum. Explain one application.
17. Prove that for a harmonic oscillator average potential energy and average kinetic energy are equal.
18. Describe the Michelson Morley experiment.
19. A plane wave of frequency 256 Hz and amplitude 0.001 mm is produced in air. Calculate the energy density and energy current, given the velocity of sound in air=332 m/s and density of air =1.29kg/m³. (Ceiling – 30)

SECTION C – Essay type

(Essays - Answer in about two pages, any one question. Answer carries 10 marks)

20. State the postulates of special theory of relativity and hence derive the Lorentz transformation equations.
21. Discuss the motion of particle under damped motion and obtain its differential equation. Write the probable solution and represent it graphically. (1 - 10 = 10 marks)

MODEL QUESTION PAPER 2

Name.....

Reg. No.....

THIRD SEMESTER B.Sc. DEGREE EXAMINATION 20.....
(CBCSS-UG)

**Complementary Course – Physics: PHY3C03-MECHANICS, RELATIVITY, WAVES AND
OSCILLATIONS**

Time: 2 Hrs

Maximum: 60 Marks

The symbols used in this question paper have their usual meanings

Section A – Short Answer type.

(Answer all questions in two or three sentences, each correct answer carries a maximum of 2 marks)

1. Explain the term Coriolis force.
2. What is meant by Galilean invariance?
3. What are fictitious forces?
4. State and explain the law of conservation of linear momentum.
5. Explain the principle of the rocket.
6. State the postulates of special relativity.
7. What is meant by time dilation?
8. How did the Michelson – Morley experiment invalidate the concept of ether?
9. What is meant by damped harmonic oscillations?
10. Explain anharmonic oscillations.
11. What are matter waves?
12. Explain uncertainty principle. (Ceiling – 20)

Section B – Paragraph / Problem type.

(Answer all questions in a paragraph of about half a page to one page, each correct answer carries a maximum of 5 marks)

13. Derive the Galilean transformation equations.
14. Explain the concept of potential energy curve.
15. Prove that for a harmonic oscillator average potential energy and average kinetic energy are equal.

16. A spring is stretched through a distance of 8 cm by a body of mass 16 kg. If the body is replaced by another body of mass 50 gm and the system undergoes oscillations, find the time period.
17. A rod has length 1 m in its rest frame. It is moving with a velocity of $0.4c$ relative to the earth. Find its length when viewed in a frame (a) moving with the rod and (b) situated on the earth.
18. A particle of mass 10 g is at rest in an inertial frame. Consider a frame rotating at an angular speed of 10 radians per second in which the body is at a distance of 5 cm from the axis of rotation. Find the Coriolis and centrifugal forces on the body in the rotating frame.
19. A stone of mass 100 g is revolved at the end of a string of length 50 cm at the rate of 2 revolutions per second. Determine its angular momentum. If the stone makes only one revolution per second after 25 seconds, find the torque applied. (Ceiling – 30)

SECTION C – Essay type

(Essays - Answer in about two pages, any one question. Answer carries 10 marks)

20. Derive Einstein's mass – energy relation and hence, obtain the relations between energy and relativistic momentum.
21. Obtain the rocket equation. State and explain the law of conservation of angular momentum with two suitable examples. (1 - 10 = 10 marks)

MODEL QUESTION PAPER -1

Name.....

Reg. No.....

FOURTH SEMESTER B.Sc. DEGREE EXAMINATION, 20.....

(CBCSS-UG)

Complementary Course – Physics: PHY4C04-ELECTRICITY, MAGNETISM AND NUCLEAR
PHYSICS

Time: 2 Hrs

Maximum: 60 Marks

The symbols used in this question paper have their usual meanings

Section A – Short Answer type.

(Answer all questions in two or three sentences, each correct answer carries a maximum of 2 marks)

1. State the law of radioactive disintegration.
2. Define a Coulomb.
3. What is latitude effect of cosmic rays?
4. State Gauss theorem in electrostatics.
5. Define electric potential and potential difference
6. Which are the fundamental interactions of nature? What is their range?
7. Write an expression for the capacitance of a cylindrical capacitor and explain the terms.
8. What is superconductivity?
9. Distinguish between nuclear fission and fusion.
10. Define mean life of a radioelement.
11. Define the unit of capacitance.
12. What are ζ , \otimes and \odot particles

(Ceiling – 20)

Section B – Paragraph / Problem type.

(Answer all questions in a paragraph of about half a page to one page, each correct answer carries a maximum of 5 marks)

13. The half-value period of radium is 1590 years. In how many years will one gram of pure element (a) lose one centigram, and (b) be reduced to one centigram?

14. Apply Gauss' s law to calculate the electric field intensity due to a uniformly charged sphere (non-conducting) at points (i) outside the sphere (ii) at the surface of the sphere (iii) inside the sphere.
15. Obtain an expression for finding the moment of a bar magnet using deflection magnetometer in Tan A position.
16. A dipole consisting of an electron and a proton, 4×10^{-10} m apart. Compute the electric field at a distance of 2×10^{-8} m on a line making an angle of 45° with the dipole axis from the centre of the dipole.
17. With the help of diagram, explain the conversion of a galvanometer to a voltmeter.
18. Write short notes on classification of elementary particles.
19. A carbon specimen found in a cave contains $1/8$ as much C^{14} as an equal amount of carbon in living matter. Calculate the approximate age of the specimen. Half-life period of C^{14} is 5568 years. (Ceiling – 30)

SECTION C – Essay type

(Essays - Answer in about two pages, any one question. Answer carries 10 marks)

20. Explain with theory how a Carey Foster bridge may be used to compare two nearly equal resistances. Hence show how the temperature coefficient of resistance can be measured.
21. Describe the construction, working and applications of a nuclear reactor.

(1 × 10 = 10 marks)

MODEL QUESTION PAPER -2

Name.....

Reg. No.....

FOURTH SEMESTER B.Sc. DEGREE EXAMINATION, 20.....

(CBCSS-UG)

Complementary Course – Physics: PHY4C04-ELECTRICITY, MAGNETISM AND NUCLEAR
PHYSICS

Time: 2 Hrs

Maximum: 60 Marks

The symbols used in this question paper have their usual meanings

Section A – Short Answer type.

(Answer all questions in two or three sentences, each correct answer carries a maximum of 2 marks)

1. Distinguish between leptons and hadrons.
2. What is a chain reaction.
3. What are primary and secondary cosmic rays?
4. Which are the magnetic elements of earth's magnetic field?
5. Define curie.
6. Which are the main elements of a nuclear fission reactor?
7. What is azimuth effect of cosmic rays?
8. Write an expression connecting current density and drift velocity of electrons?
9. Write down Coulomb's law in electrostatics and explain the terms.
10. Define half-life of a radioelement.
11. What are isobars? Give examples.
12. Write an expression for the capacitance of a cylindrical capacitor and explain the terms.

(Ceiling – 20)

Section B – Paragraph / Problem type.

(Answer all questions in a paragraph of about half a page to one page, each correct answer carries a maximum of 5 marks)

13. Calculate the energy released by 1kg of ${}_{92}\text{U}^{235}$. Given Avogadro number = 6.023×10^{26} .

14. A copper wire of diameter 0.5mm and length 20m is connected across a battery of emf 1.5V and internal resistance 1.25Ω . Calculate the current density in the wire. Given atomic weight of copper = 63.54.
15. Obtain an expression for finding the moment of a bar magnet using deflection magnetometer in Tan C position.
16. The radii of spheres in a spherical capacitor are 5cm and 8cm. The outer sphere is earthed and the inner sphere is given a charge of $0.005 \mu\text{C}$. Calculate the potential difference.
17. Calculate the binding energy of an α particle and express the result both in MeV and joules.
18. The number of disintegrations per minute of a certain radioactive substance are 6050 and 4465 at the 2nd and 3rd hour. Calculate the decay constant and half-life of the substance.
19. How long does it take for 60% of a sample of Radon to decay? Half-life of Radon = 3.8 days. (Ceiling – 30)

SECTION C – Essay type

(Essays - Answer in about two pages, any one question. Answer carries 10 marks)

20. Derive an expression for the capacitance of a parallel plate capacitor. What will be the capacitance if the space between the plates is partially filled with a slab of thickness d and relative permittivity ϵ_r ?
21. With the help of a neat diagram, explain the construction and working of a Searle's vibration magnetometer. (1 · 10 = 10 marks)